

**STANLEY**®

**FatMax**®

23

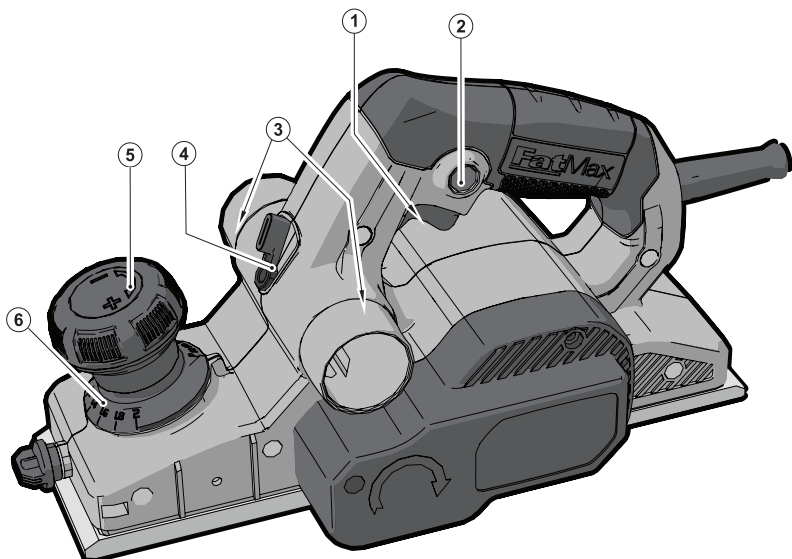

[www.stanley.eu](http://www.stanley.eu)

**FME630**

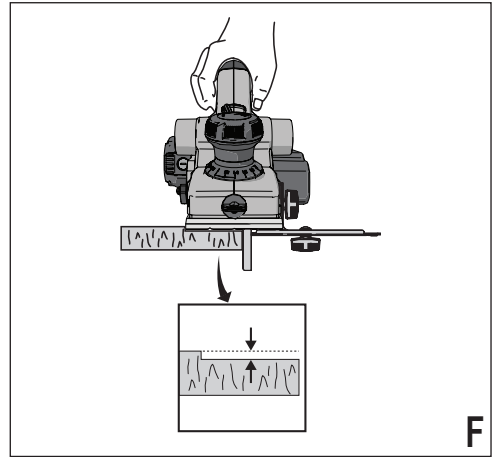
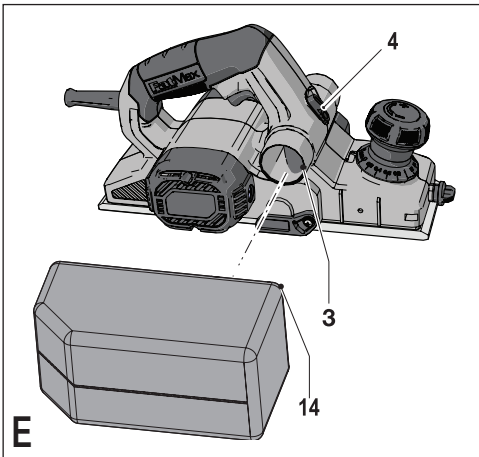
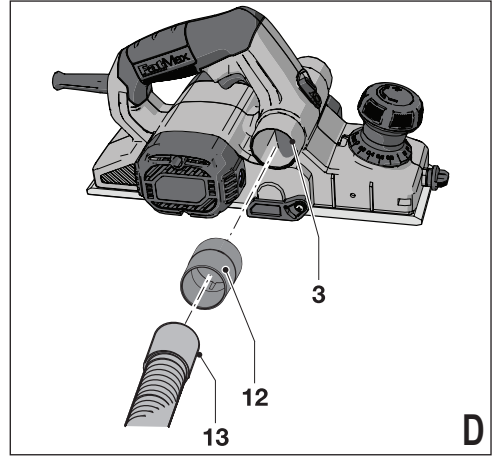
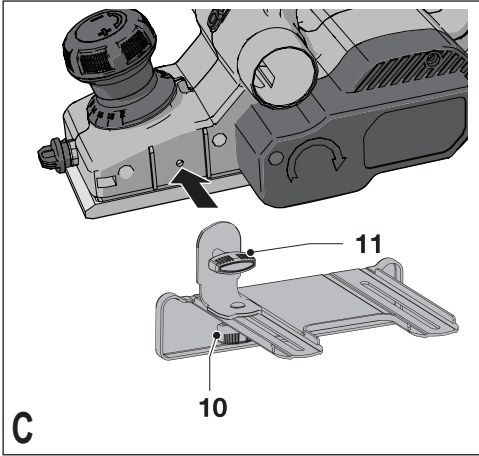
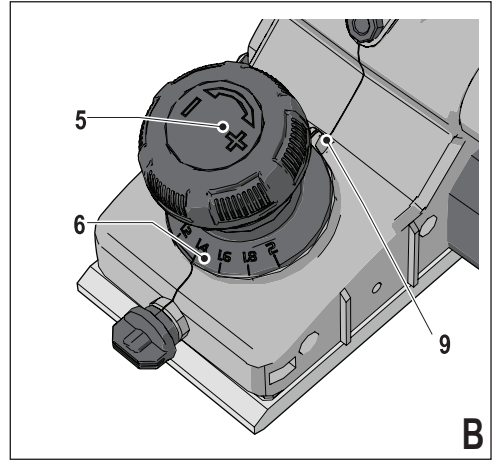
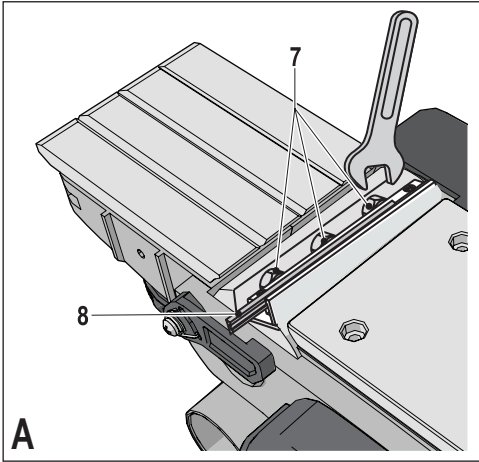

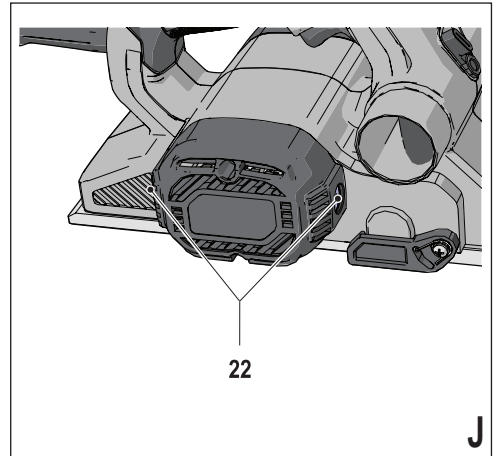
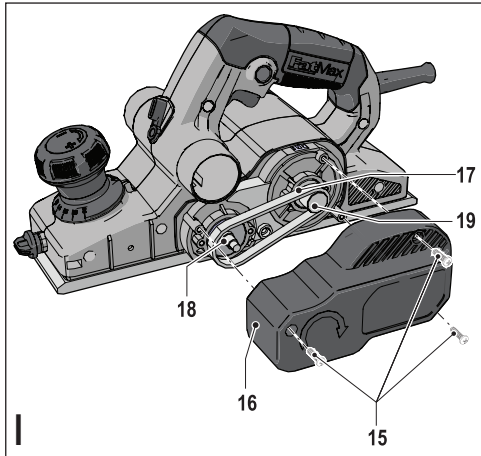
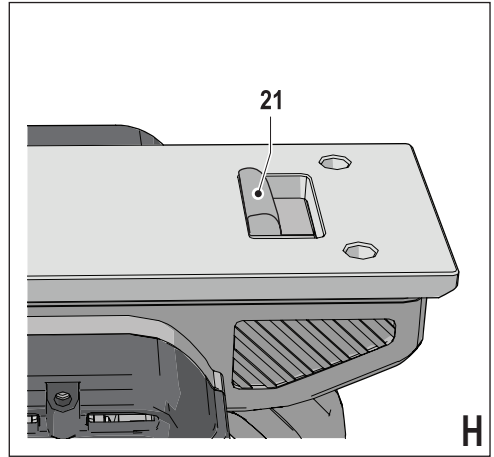
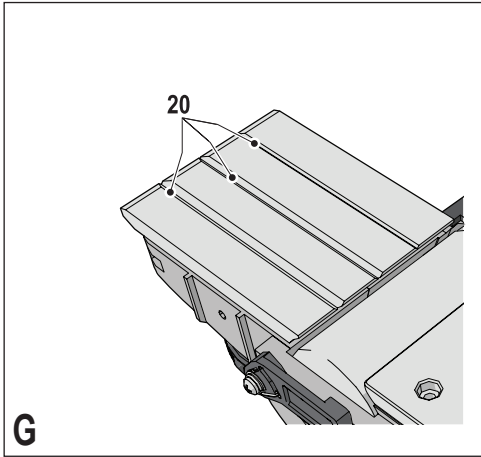

## Intended use

Your Stanley Fat Max planer has been designed for planing wood, wood products and plastics. This tool is intended for professional and private, non professional users.

## Safety instructions

### General power tool safety warnings



**Warning! Read all safety warnings and all instructions.** Failure to follow the warnings and instructions listed below may result in electric shock, fire and/or serious injury.

### Save all warnings and instructions for future reference.

The term "power tool" in all of the warnings listed below refers to your mains operated (corded) power tool or battery operated (cordless) power tool.

1. **Work area safety**
  - a. **Keep work area clean and well lit.** Cluttered or dark areas invite accidents.
  - b. **Do not operate power tools in explosive atmospheres, such as in the presence of flammable liquids, gases or dust.** Power tools create sparks which may ignite the dust or fumes.
  - c. **Keep children and bystanders away while operating a power tool.** Distractions can cause you to lose control.
2. **Electrical safety**
  - a. **Power tool plugs must match the outlet. Never modify the plug in any way. Do not use any adapter plugs with earthed (grounded) power tools.** Unmodified plugs and matching outlets will reduce risk of electric shock.
  - b. **Avoid body contact with earthed or grounded surfaces such as pipes, radiators, ranges and refrigerators.** There is an increased risk of electric shock if your body is earthed or grounded.
  - c. **Do not expose power tools to rain or wet conditions.** Water entering a power tool will increase the risk of electric shock.
  - d. **Do not abuse the cord. Never use the cord for carrying, pulling or unplugging the power tool. Keep cord away from heat, oil, sharp edges or moving parts.** Damaged or entangled cords increase the risk of electric shock.
  - e. **When operating a power tool outdoors, use an extension cord suitable for outdoor use.** Use of a cord suitable for outdoor use reduces the risk of electric shock.
  - f. **If operating a power tool in a damp location is unavoidable, use a residual current device (RCD) protected supply.** Use of an RCD reduces the risk of electric shock.
3. **Personal safety**
  - a. **Stay alert, watch what you are doing and use common sense when operating a power tool. Do not use a power tool while you are tired or under the influence of drugs, alcohol or medication.** A moment of inattention while operating power tools may result in serious personal injury.
  - b. **Use personal protective equipment. Always wear eye protection.** Protective equipment such as dust mask, non-skid safety shoes, hard hat, or hearing protection used for appropriate conditions will reduce personal injuries.
  - c. **Prevent unintentional starting. Ensure the switch is in the off-position before connecting to power source and/or battery pack, picking up or carrying the tool.** Carrying power tools with your finger on the switch or energising power tools that have the switch on invites accidents.
  - d. **Remove any adjusting key or wrench before turning the power tool on.** A wrench or a key left attached to a rotating part of the power tool may result in personal injury.
  - e. **Do not overreach. Keep proper footing and balance at all times.** This enables better control of the power tool in unexpected situations.
  - f. **Dress properly. Do not wear loose clothing or jewellery. Keep your hair, clothing and gloves away from moving parts.** Loose clothes, jewellery or long hair can be caught in moving parts.
  - g. **If devices are provided for the connection of dust extraction and collection facilities, ensure these are connected and properly used.** Use of dust collection can reduce dust-related hazards.
4. **Power tool use and care**
  - a. **Do not force the power tool. Use the correct power tool for your application.** The correct power tool will do the job better and safer at the rate for which it was designed.
  - b. **Do not use the power tool if the switch does not turn it on and off.** Any power tool that cannot be controlled with the switch is dangerous and must be repaired.
  - c. **Disconnect the plug from the power source and/or the battery pack from the power tool before making any adjustments, changing accessories, or storing power tools.** Such preventive safety measures reduce the risk of starting the power tool accidentally.

- d. **Store idle power tools out of the reach of children and do not allow persons unfamiliar with the power tool or these instructions to operate the power tool.** Power tools are dangerous in the hands of untrained users.
  - e. **Maintain power tools. Check for misalignment or binding of moving parts, breakage of parts and any other condition that may affect the power tools operation. If damaged, have the power tool repaired before use.** Many accidents are caused by poorly maintained power tools.
  - f. **Keep cutting tools sharp and clean.** Properly maintained cutting tools with sharp cutting edges are less likely to bind and are easier to control.
  - g. **Use the power tool, accessories and tool bits etc., in accordance with these instructions, taking into account the working conditions and the work to be performed.** Use of the power tool for operations different from those intended could result in a hazardous situation.
5. **Service**
- a. **Have your power tool serviced by a qualified repair person using only identical replacement parts.** This will ensure that the safety of the power tool is maintained.

### Additional power tool safety warnings



**Warning!** Additional safety warnings for planers

- ◆ **Hold the power tool by insulated gripping surfaces only, because the cutter may contact its own cord.** Cutting a "live" wire may make exposed metal parts of the power tool "live" and could give the operator an electric shock.
- ◆ **Use clamps or another practical way to secure and support the workpiece to a stable platform.** Holding the work by your hand or against the body leaves it unstable and may lead to loss of control.
- ◆ **Wait for the cutter to stop before setting the tool down.** An exposed rotating cutter may engage the surface leading to possible loss of control and serious injury.
- ◆ **Keep the cutter sharp.** Dull or damaged cutters may cause the planer to swerve or stall under pressure. Always use the appropriate type of cutter for the power tool.
- ◆ Do not touch the workpiece or the cutter immediately after operating the tool. They can become very hot.
- ◆ Remove all nails and metal objects from the workpiece before planning.
- ◆ Always hold the tool with both hands and by the handles provided.
- ◆ Immediately disconnect the cable from the mains if it is damaged or cut.

**Warning!** Contact with, or inhalation of dusts arising from planing applications may endanger the health of the operator and possible bystanders. Wear a dust mask specifically designed for protection against dust and fumes and ensure that persons within or entering the work area are also protected.

- ◆ This tool is not intended for use by persons (including children) with reduced physical, sensory or mental capabilities, or lack of experience and knowledge, unless they have been given supervision or instruction concerning use of the appliance by a person responsible for their safety. Children should be supervised to ensure that they do not play with the appliance.
- ◆ The intended use is described in this instruction manual. The use of any accessory or attachment or performance of any operation with this tool other than those recommended in this instruction manual may present a risk of personal injury and/or damage to property.

### Safety of others

- ◆ This appliance is not intended for use by persons (including children) with reduced physical, sensory or mental capabilities, or lack of experience and knowledge, unless they have been given supervision or instruction concerning use of the appliance by a person responsible for their safety.
- ◆ Children should be supervised to ensure that they do not play with the appliance.

### Residual risks.

Additional residual risks may arise when using the tool which may not be included in the enclosed safety warnings. These risks can arise from misuse, prolonged use etc.

Even with the application of the relevant safety regulations and the implementation of safety devices, certain residual risks can not be avoided. These include:

- ◆ Injuries caused by touching any rotating/moving parts.
- ◆ Injuries caused when changing any parts, blades or accessories.
- ◆ Injuries caused by prolonged use of a tool. When using any tool for prolonged periods ensure you take regular breaks.
- ◆ Impairment of hearing.
- ◆ Health hazards caused by breathing dust developed when using your tool (example:- working with wood, especially oak, beech and MDF.)

### Vibration

The declared vibration emission values stated in the technical data and the declaration of conformity have been measured in accordance with a standard test method provided by EN 60745 and may be used for comparing one tool with another. The declared vibration emission value may also be used in a preliminary assessment of exposure.

**Warning!** The vibration emission value during actual use of the power tool can differ from the declared value depending on the ways in which the tool is used. The vibration level may increase above the level stated.

When assessing vibration exposure to determine safety measures required by 2002/44/EC to protect persons regularly using power tools in employment, an estimation of vibration exposure should consider, the actual conditions of use and the way the tool is used, including taking account of all parts of the operating cycle such as the times when the tool is switched off and when it is running idle in addition to the trigger time.

### Labels on tool

The following pictograms are shown on the tool:



**Warning!** To reduce the risk of injury, the user must read the instruction manual.

### Electrical safety



This tool is double insulated; therefore no earth wire is required. Always check that the power supply corresponds to the voltage on the rating plate.

- ◆ If the supply cord is damaged, it must be replaced by the manufacturer or an authorised Stanley Fat Max Service Centre in order to avoid a hazard.

### Features

This tool includes some or all of the following features.

1. On/off switch
2. Lock-off button
3. Shavings discharge outlet
4. Shavings discharge outlet selector
5. Planing depth adjustment knob
6. Planing depth graduation

### Assembly

**Warning!** Before assembly, make sure that the tool is switched off and unplugged.

### Replacing the cutting blades (fig. A)

The cutting blades provided with this tool are reversible. Replacement cutting blades can be obtained from your local retailer.

### Removing

- ◆ Loosen the bolts (7) using the spanner supplied.
- ◆ Slide the blade (8) out of the holder.
- ◆ Reverse the blade so that the unused side comes in position. If both sides are worn, the blade must be replaced.

### Fitting

- ◆ Slide the blade into the holder until it is against the end stop.
- ◆ Tighten the bolts using the spanner supplied.

**Warning!** Always replace both cutters.

### Adjusting the depth of cut (fig. B)

The depth of cut is indicated by the marking (9). The setting range can be read from the graduation (6).

- ◆ Turn the planing depth adjustment knob (5) to the required depth of cut.
- ◆ Turn the knob to the 'P' position whenever the tool is not in use.

### Fitting and removing the parallel fence (fig. C)

The parallel fence is used to for optimum control on narrow workpieces.

- ◆ Thread the knob (11) into the hole on the side of the planer and securely tighten.
- ◆ Loosen the parallel fence adjustment knob (10).
- ◆ Slide the parallel fence into the desired position.
- ◆ Securely tighten the parallel fence adjustment knob.

**Note :** The parallel fence should be below the planer when installed correctly.

- ◆ To remove the parallel fence proceed in reverse order.

### Connecting a vacuum cleaner to the tool (fig. D)

An adaptor is required to connect a vacuum cleaner or dust extractor to the tool. The adaptor can be purchased from your local Stanley Fat Max retailer.

- ◆ Slide the adaptor (12) over the shavings discharge outlet (3).
- ◆ Connect the vacuum cleaner hose (13) to the adaptor.

### Fitting the shavings collection bag (fig. E)

The shavings collection bag is particularly useful when working in confined spaces.

- ◆ Slide the connecting plate (14) of the bag over either side of the shavings discharge outlet (3).
- ◆ To prevent chips from coming out opposite side of shavings discharge outlet, move the shavings discharge outlet selector (4) to the opposite side from the bag.

### Emptying the shavings collection bag

The shavings collection bag should be emptied regularly while using it to prevent blocking.

- ◆ Unzip the bag and empty it before continuing.

## Use

**Warning!** Let the tool work at its own pace. Do not overload.

- ◆ Adjust the depth of cut.
- ◆ If necessary, fit and adjust the parallel fence.

## Switching on and off

### Switching on

- ◆ Keep the lock-off button (2) depressed and press the on/off switch (1).
- ◆ Release the lock-off button.

### Switching off

- ◆ Release the on/off switch.

## Planing

- ◆ Hold the tool with the nose piece of the shoe resting on top of the workpiece surface.
- ◆ Switch the tool on.
- ◆ Move the tool steadily forward to perform the cutting stroke.
- ◆ Switch the tool off after the stroke has been completed.

## Rebating (fig. F)

- ◆ Fit and adjust the parallel fence.
- ◆ Proceed as for planing.

## Chamfering edges (fig. G)

The V-groove in the nose piece of the shoe enables you to chamfer edges at 45°, 30° and 15° angles.

- ◆ Hold the tool at an angle with the desired groove (20) around the edge of the workpiece and perform the cutting stroke.

## Parking rest (fig. H)

Your planer is equipped with a parking rest (21) that automatically lowers into place when the tool is lifted from the work surface. When planing, the parking foot raises as the tool is pushed forward. When the parking foot is lowered, the planer can set on the work surface without the blade touching.

## Hints for optimum use

- ◆ Move the tool along the grain of the wood.
- ◆ If the grain is cross or curly, or if the workpiece material is a hard type of wood, adjust the depth of cut to take only a very thin shaving at each pass and take several passes to achieve the desired result.
- ◆ To keep the tool in a straight line, press down the front of the tool at the start, and press down the back of the tool at the end of the cutting stroke.

## Accessories

The performance of your tool depends on the accessory used. Stanley Fat Max accessories are engineered to high quality standards and designed to enhance the performance of your tool. By using these accessories you will get the very best from your tool.

The following types of cutting blades can be obtained from your local retailer:

- Tungsten carbide tipped reversible cutting blades (part no. X35007, supplied per pair)
- High-speed steel reversible cutting blades (part no. X24192-XJ11, supplied per pair)

## Maintenance

Your tool has been designed to operate over a long period of time with a minimum of maintenance. Continuous satisfactory operation depends upon proper tool care and regular cleaning.

**Warning!** Before performing any maintenance, switch off and unplug the tool.

- ◆ Regularly clean the ventilation slots in your tool using a soft brush or dry cloth.
- ◆ Regularly clean the motor housing using a damp cloth. Do not use any abrasive or solvent-based cleaner.

## Replacing the drive belt (fig. I)

- ◆ Loosen the screws (15) and remove the cover (16).
- ◆ Remove the old drive belt.
- ◆ Place the new belt (17) over the pulleys. Place the belt over the large pulley (18) first, then over the small pulley (19), whilst manually rotating the belt steadily.
- ◆ Put the cover back in place and tighten the screws.

## Motor brush inspection and replacement (fig. J)

Brushes should be regularly inspected for wear.

- ◆ Remove brush cap (22). The brushes should slide freely in brush box. If brushes are worn down to .3" (8mm) they should be replaced.

To reinstall, push new brush back into brush box. If replacing existing brush, maintain same orientation as when removed. Replace the brush cap (do not overtighten).

## Mains plug replacement (U.K. & Ireland only)

If a new mains plug needs to be fitted:

- ◆ Safely dispose of the old plug.
- ◆ Connect the brown lead to the live terminal in the new plug.
- ◆ Connect the blue lead to the neutral terminal.

**Warning!** No connection is to be made to the earth terminal. Follow the fitting instructions supplied with good quality plugs. Recommended fuse: 5 A.

## Protecting the environment



Separate collection. This product must not be disposed of with normal household waste.

Should you find one day that your Stanley Fat Max product needs replacement, or if it is of no further use to you, do not dispose of it with household waste. Make this product available for separate collection.



Separate collection of used products and packaging allows materials to be recycled and used again. Re-use of recycled materials helps prevent environmental pollution and reduces the demand for raw materials.

Local regulations may provide for separate collection of electrical products from the household, at municipal waste sites or by the retailer when you purchase a new product.

Stanley Europe provides a facility for the collection and recycling of Stanley Fat Max products once they have reached the end of their working life. To take advantage of this service please return your product to any authorised repair agent who will collect them on our behalf.

You can check the location of your nearest authorised repair agent by contacting your local Stanley Europe office at the address indicated in this manual. Alternatively, a list of authorised Stanley Europe repair agents and full details of our after-sales service and contacts are available on the Internet at: [www.2helpU.com](http://www.2helpU.com)

## Technical data

		FME630 (Type 1)
Input voltage	V <sub>ac</sub>	230
Power input	W	750
No-load speed	min <sup>-1</sup>	16,500
Planing width	mm	82
Planing depth	mm	2
Rebating depth	mm	12
Weight	kg	2.9

Vibration total values (triax vector sum) according to EN 60745:
Vibration emission value (a <sub>H</sub> ) 1.5 m/s <sup>2</sup>
uncertainty (K) 1.5 m/s <sup>2</sup>
Level of sound pressure according to EN 60745:
Sound pressure (L <sub>pA</sub> ) 84 dB(A), uncertainty (K) 3 dB(A)
Sound power (L <sub>WA</sub> ) 95 dB(A), uncertainty (K) 3 dB(A)

## EC declaration of conformity

MACHINERY DIRECTIVE



FME630

Stanley Europe declares that these products described under "technical data" are in compliance with:

2006/42/EC

EN 60745-1, EN 60745-2-14

These products also comply with Directive 2004/108/EC and 2011/65/EU. For more information, please contact Stanley Europe at the following address or refer to the back of the manual.

The undersigned is responsible for compilation of the technical file and makes this declaration on behalf of Stanley Europe.

Kevin Hewitt  
Vice-President Global Engineering  
Stanley Europe, Egide Walschaertsstraat14-18,  
2800 Mechelen, Belgium  
28/08/2012



## Guarantee

StanleyEurope is confident of the quality of its products and offers an outstanding guarantee for professional users of the product. This guarantee statement is in addition to and in no way prejudices your contractual rights as a private non-professional user. The guarantee is valid within the territories of the Member States of the European Union and the European Free Trade Area.

## ONE-YEAR FULL WARRANTY

If your Stanley Fat Max product becomes defective due to faulty materials or workmanship within 12 months from the date of purchase, Stanley Europe guarantees to replace all defective parts free of charge or – at our discretion – replace the unit free of charge provided that:

- ◆ The product has not been misused and has been used in accordance with the instruction manual.
- ◆ The product has been subject to fair wear and tear;
- ◆ Repairs have not been attempted by unauthorised persons;
- ◆ Proof of purchase is produced.
- ◆ The Stanley Fat Max product is returned complete with all original components

If you wish to make a claim, contact your seller or check the location of your nearest authorised Stanley Fat Max repair agent in the Stanley Fat Max catalogue or contact your local Stanley office at the address indicated in this manual. A list of authorised Stanley Fat Max repair agents and full details of our after sales service is available on the internet at:[www.stanley.eu/3](http://www.stanley.eu/3)

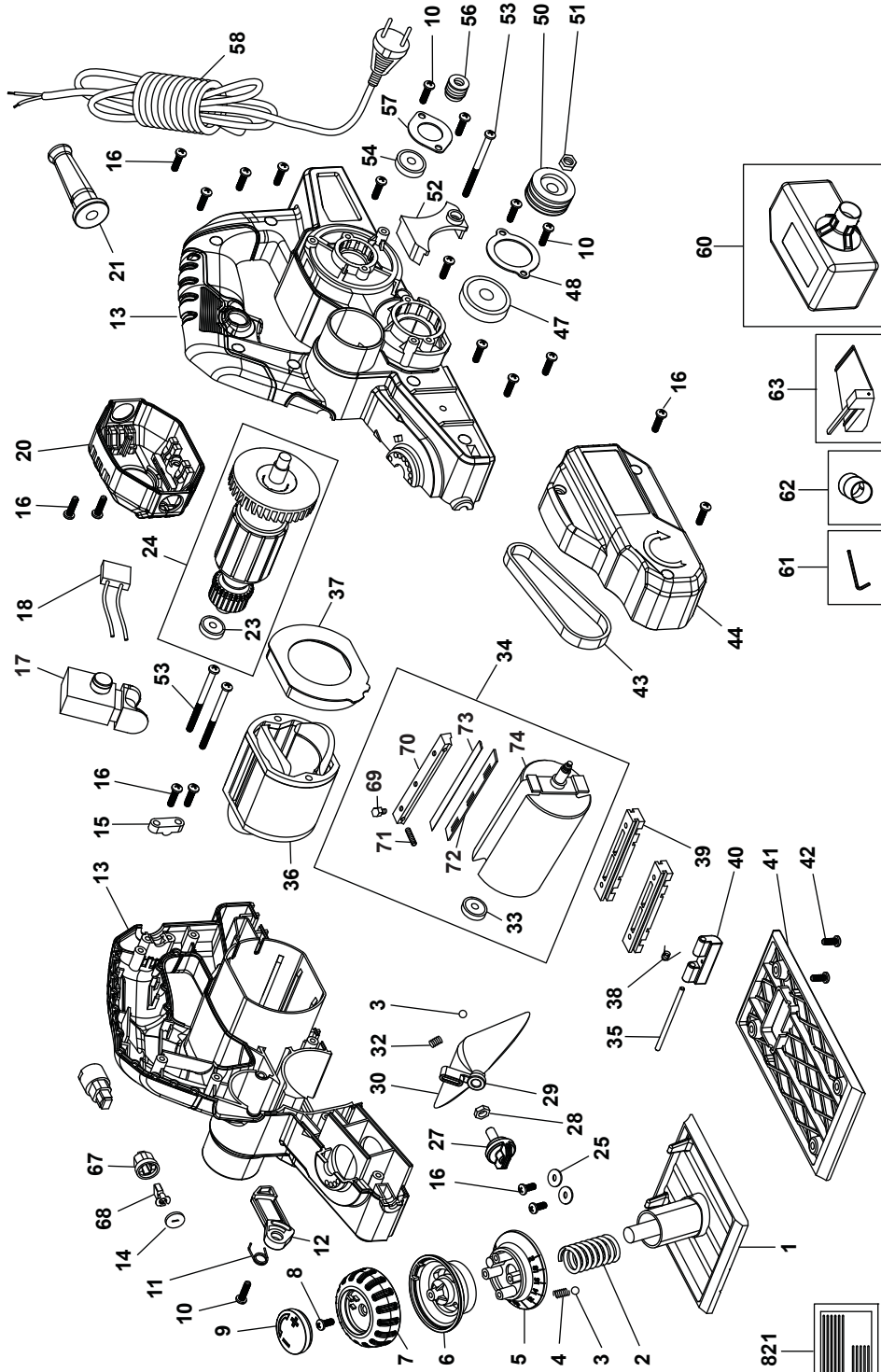



**United Kingdom**  
Stanley Fat Max  
210 Bath Road  
Slough, Berkshire SL1 3YD

Tel. 01753 511234  
Fax 01753 572112  
[www.stanleytools.co.uk](http://www.stanleytools.co.uk)