

# STANLEY®

## FATMAX®

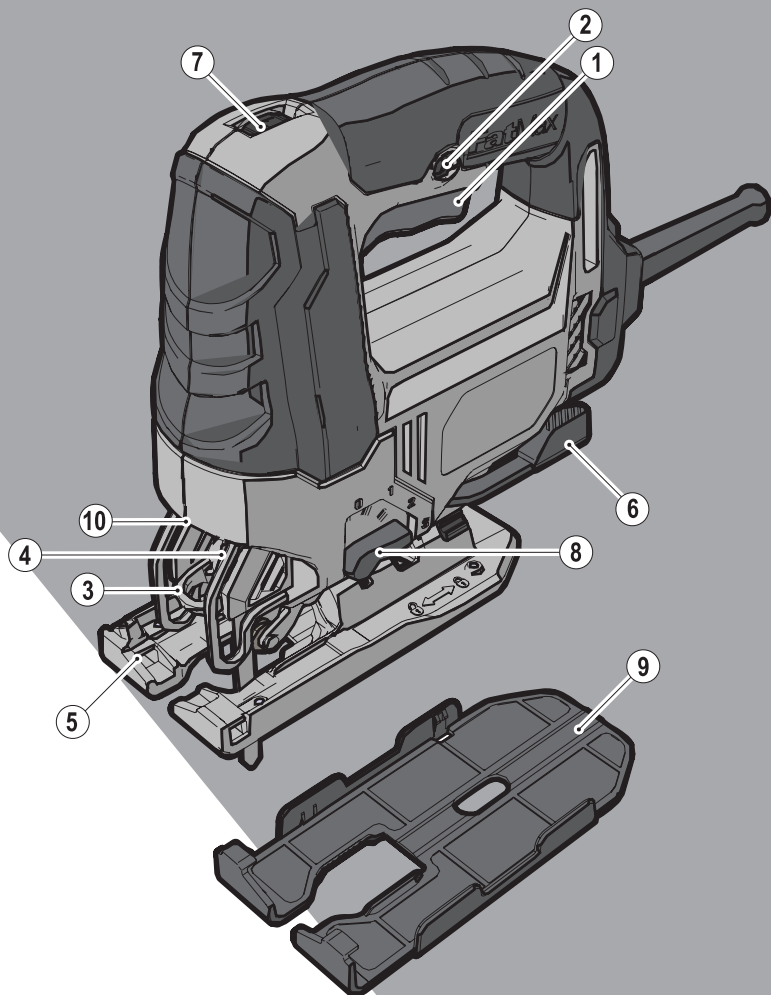

FME340

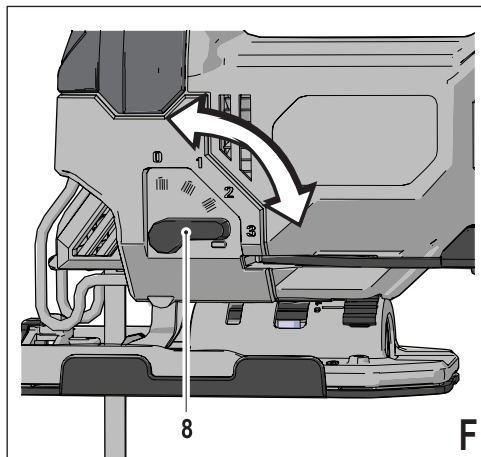
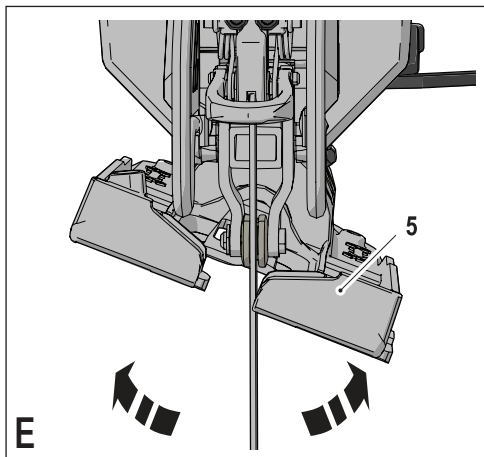
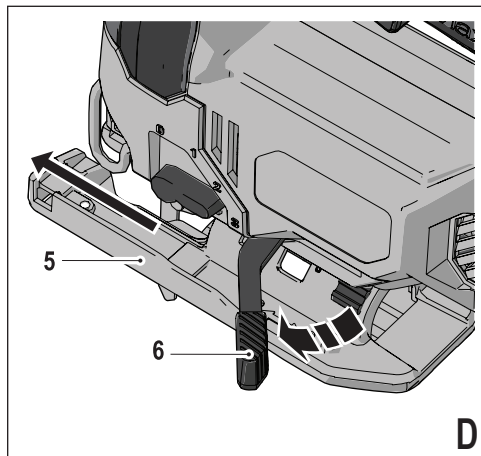
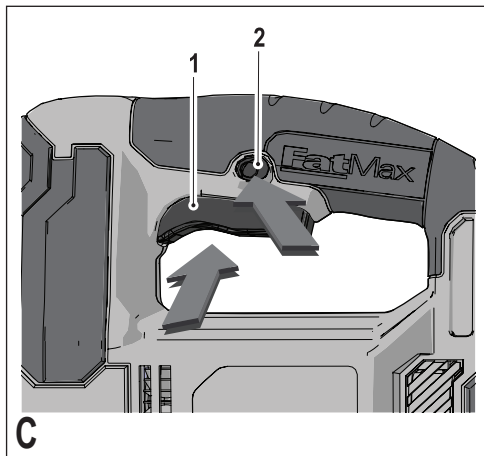
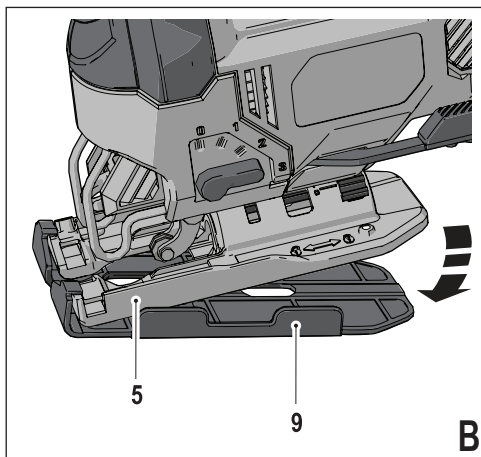
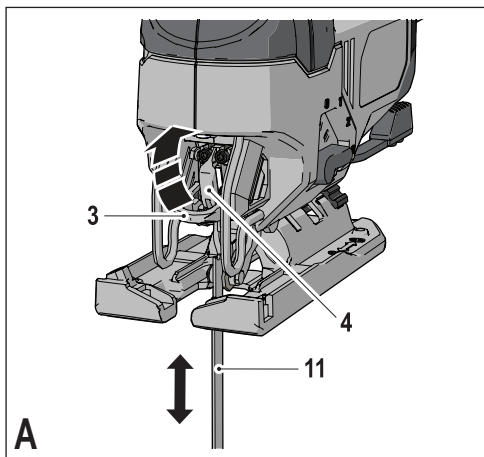

## Intended use

Your Stanley FatMax jigsaw has been designed for sawing wood, plastics and sheet metal. This tool is intended for professional and private, non professional users.

## Safety instructions

### General power tool safety warnings



**Warning!** Read all safety warnings and all instructions. Failure to follow the warnings and instructions listed below may result in electric shock, fire and/or serious injury.

### Save all warnings and instructions for future reference.

The term "power tool" in all of the warnings listed below refers to your mains operated (corded) power tool or battery operated (cordless) power tool.

1. **Work area safety**
  - a. **Keep work area clean and well lit.** Cluttered or dark areas invite accidents.
  - b. **Do not operate power tools in explosive atmospheres, such as in the presence of flammable liquids, gases or dust.** Power tools create sparks which may ignite the dust or fumes.
  - c. **Keep children and bystanders away while operating a power tool.** Distractions can cause you to lose control.
2. **Electrical safety**
  - a. **Power tool plugs must match the outlet. Never modify the plug in any way. Do not use any adapter plugs with earthed (grounded) power tools.** Unmodified plugs and matching outlets will reduce risk of electric shock.
  - b. **Avoid body contact with earthed or grounded surfaces such as pipes, radiators, ranges and refrigerators.** There is an increased risk of electric shock if your body is earthed or grounded.
  - c. **Do not expose power tools to rain or wet conditions.** Water entering a power tool will increase the risk of electric shock.
  - d. **Do not abuse the cord. Never use the cord for carrying, pulling or unplugging the power tool. Keep cord away from heat, oil, sharp edges or moving parts.** Damaged or entangled cords increase the risk of electric shock.
  - e. **When operating a power tool outdoors, use an extension cord suitable for outdoor use.** Use of a cord suitable for outdoor use reduces the risk of electric shock.
  - f. **If operating a power tool in a damp location is unavoidable, use a residual current device (RCD) protected supply.** Use of an RCD reduces the risk of electric shock.
3. **Personal safety**
  - a. **Stay alert, watch what you are doing and use common sense when operating a power tool. Do not use a power tool while you are tired or under the influence of drugs, alcohol or medication.** A moment of inattention while operating power tools may result in serious personal injury.
  - b. **Use personal protective equipment. Always wear eye protection.** Protective equipment such as dust mask, non-skid safety shoes, hard hat, or hearing protection used for appropriate conditions will reduce personal injuries.
  - c. **Prevent unintentional starting. Ensure the switch is in the off-position before connecting to power source and/or battery pack, picking up or carrying the tool.** Carrying power tools with your finger on the switch or energising power tools that have the switch on invites accidents.
  - d. **Remove any adjusting key or wrench before turning the power tool on.** A wrench or a key left attached to a rotating part of the power tool may result in personal injury.
  - e. **Do not overreach. Keep proper footing and balance at all times.** This enables better control of the power tool in unexpected situations.
  - f. **Dress properly. Do not wear loose clothing or jewellery. Keep your hair, clothing and gloves away from moving parts.** Loose clothes, jewellery or long hair can be caught in moving parts.
  - g. **If devices are provided for the connection of dust extraction and collection facilities, ensure these are connected and properly used.** Use of dust collection can reduce dust-related hazards.
4. **Power tool use and care**
  - a. **Do not force the power tool. Use the correct power tool for your application.** The correct power tool will do the job better and safer at the rate for which it was designed.
  - b. **Do not use the power tool if the switch does not turn it on and off.** Any power tool that cannot be controlled with the switch is dangerous and must be repaired.
  - c. **Disconnect the plug from the power source and/or the battery pack from the power tool before making any adjustments, changing accessories, or storing power tools.** Such preventive safety measures reduce the risk of starting the power tool accidentally.
  - d. **Store idle power tools out of the reach of children and do not allow persons unfamiliar with the power tool or these instructions to operate the power tool.** Power tools are dangerous in the hands of untrained users.

- e. **Maintain power tools.** Check for misalignment or binding of moving parts, breakage of parts and any other condition that may affect the power tools operation. If damaged, have the power tool repaired before use. Many accidents are caused by poorly maintained power tools.
  - f. **Keep cutting tools sharp and clean.** Properly maintained cutting tools with sharp cutting edges are less likely to bind and are easier to control.
  - g. **Use the power tool, accessories and tool bits etc. in accordance with these instructions, taking into account the working conditions and the work to be performed.** Use of the power tool for operations different from those intended could result in a hazardous situation.
5. **Service**
- a. **Have your power tool serviced by a qualified repair person using only identical replacement parts.** This will ensure that the safety of the power tool is maintained.
  - b. **Power to the tool should always be supplied via residual current device with a rated residual current of 30mA or less.**

### Additional power tool safety warnings



**Warning!** Additional safety warnings for jigsaws and reciprocating saws

- ◆ **Hold power tool by insulated gripping surfaces, when performing an operation where the cutting accessory may contact hidden wiring or its own cord.** Cutting accessory contacting a "live" wire may make exposed metal parts of the power tool "live" and could give the operator an electric shock.
- ◆ **Use clamps or another practical way to secure and support the workpiece to a stable platform.** Holding the work by hand or against your body leaves it unstable and may lead to loss of control.
- ◆ **Keep hands away from cutting area.** Never reach underneath the work piece any reason. Do not insert fingers or thumb into the vicinity of the reciprocating blade and blade clamp. Do not stabilize the saw by gripping the shoe.
- ◆ **Keep blades sharp.** Dull or damaged blades may cause the saw to swerve or stall under pressure. Always use the appropriate type of saw blade for the workpiece material and type of cut.
- ◆ **When cutting pipe or conduit, make sure that they are free from water, electrical wiring, etc.**
- ◆ **Do not touch the workpiece or the blade immediately after operating the tool.** They can become very hot.

- ◆ **Be aware of hidden hazards, before cutting into walls, floors or ceilings, check for the location of wiring and pipes.**
- ◆ **The blade will continue to move after releasing the switch.** Always switch the tool off and wait for the saw blade to come to a complete standstill before putting the tool down.

**Warning!** Contact with, or inhalation of dusts arising from cutting applications may endanger the health of the operator and possible bystanders. Wear a dust mask specifically designed for protection against dust and fumes and ensure that persons within or entering the work area are also protected.

- ◆ The intended use is described in this instruction manual. The use of any accessory or attachment or performance of any operation with this tool other than those recommended in this instruction manual may present a risk of personal injury and/or damage to property.

### Safety of others

- ◆ This tool is not intended for use by persons (including children) with reduced physical, sensory or mental capabilities, or lack of experience and knowledge, unless they have been given supervision or instruction concerning use of the appliance by a person responsible for their safety.
- ◆ Children should be supervised to ensure that they do not play with the appliance.

### Residual risks.

Additional residual risks may arise when using the tool which may not be included in the enclosed safety warnings. These risks can arise from misuse, prolonged use etc. Even with the application of the relevant safety regulations and the implementation of safety devices, certain residual risks can not be avoided. These include:

- ◆ Injuries caused by touching any rotating/moving parts.
- ◆ Injuries caused when changing any parts, blades or accessories.
- ◆ Injuries caused by prolonged use of a tool. When using any tool for prolonged periods ensure you take regular breaks.
- ◆ Impairment of hearing.
- ◆ Health hazards caused by breathing dust developed when using your tool (example:- working with wood, especially oak, beech and MDF.)

### Vibration

The declared vibration emission values stated in the technical data and the declaration of conformity have been measured in accordance with a standard test method provided by EN 60745 and may be used for comparing one tool with another. The declared vibration emission value may also be used in a preliminary assessment of exposure.

**Warning!** The vibration emission value during actual use of the power tool can differ from the declared value depending on the ways in which the tool is used. The vibration level may increase above the level stated.

When assessing vibration exposure to determine safety measures required by 2002/44/EC to protect persons regularly using power tools in employment, an estimation of vibration exposure should consider, the actual conditions of use and the way the tool is used, including taking account of all parts of the operating cycle such as the times when the tool is switched off and when it is running idle in addition to the trigger time.

### Labels on tool

The following symbols are shown on the tool:



**Warning!** To reduce the risk of injury, the user must read the instruction manual.

### Electrical safety



This tool is double insulated; therefore no earth wire is required. Always check that the power supply corresponds to the voltage on the rating plate.

- ◆ If the supply cord is damaged, it must be replaced by the manufacturer or an authorised Stanley FaxMax Service Centre in order to avoid a hazard.

### Features

This tool includes some or all of the following features.

1. Trigger switch
2. Lock-on button
3. Saw blade locking lever
4. Blade clamp
5. Shoe plate
6. Shoe beveling lever
7. Variable speed control
8. Cutting action lever
9. Shoe sleeve
10. LED work light

### Assembly

**Warning!** Before assembly, remove the battery from the tool and make sure that the saw blade has stopped. Used saw blades may be hot.

### Fitting and removing the saw blade (fig. A)

- ◆ Hold the saw blade (11) with the teeth facing forward.
- ◆ Lift the saw blade locking lever (3) upwards.

- ◆ Insert the shank of the blade fully into the blade clamp (4) as far as it will go.
- ◆ Release the lever.
- ◆ To remove the saw blade (11), lift the saw blade locking lever (3) upwards and pull the blade out.

### Fitting and removing the shoe sleeve (fig. B)

The non scratch shoe sleeve (9) should be used when cutting surfaces that scratch easily, such as laminate, veneer, or paint. It can also be used to protect the shoe surface during transportation and storage.

#### To attach shoe sleeve:

- ◆ place the front of the shoe plate (5) into the front of the shoe sleeve (9).
- ◆ Lower the tool into the shoe sleeve (9). The shoe sleeve will click securely onto the rear of the shoe.

#### To remove shoe sleeve:

- ◆ Grasp the shoe sleeve from the bottom at the two rear tabs and pull down and away from the shoe plate (5).

### Use

**Warning!** Let the tool work at its own pace. Do not overload.

**Warning!** Never use the tool when the saw shoe is loose or removed.

### Switching on and off (fig. C)

**Warning!** Check that the tool is not locked ON before connecting it to a power supply. If the trigger switch is locked ON when the tool is connected to the power supply, it will start immediately. Damage to your tool or personal injury may result..

- ◆ To switch the tool on, press the trigger switch (1). The tool speed depends on how far you press the switch.
- ◆ For continuous operation, press the lock-on button (2) and release the variable speed switch. This option is available only at full speed.
- ◆ To switch the tool off, release the trigger switch. To switch the tool off when in continuous operation, press the trigger switch once more and release it.

### Variable speed control

The variable speed on/off switch offers a choice of speeds for greatly improved cutting rates in various materials.

- ◆ To set the speed, turn the variable speed control (7) to the required setting.

### Bevel cutting (fig. D & E)

The shoe plate can be set to a left or right bevel angle of up to 45°.

**To set the bevel angle:**

- ◆ Pull the shoe beveling lever (6) out and away from the saw to unlock the shoe plate (5).
- ◆ Slide the shoe plate forward to release it from the 0° positive stop position.
- ◆ Set the shoe plate to the desired bevel angle. Use a protractor to verify angle accuracy.
- ◆ Push the shoe beveling lever (6) back towards the saw to lock the shoe plate (5).

**Note:** The shoe can be beveled to the left or to the right and has detents at 15°, 30° and 45°.

**To reset the shoe for straight cuts:**

- ◆ Pull the shoe beveling lever (6) out and away from the saw to unlock the shoe plate (5).
- ◆ Rotate shoe to an angle of approximately 0° and then pull shoe backwards to engage the 0° positive stop.
- ◆ Push the shoe beveling lever back (6) towards the saw to lock the shoe plate (5).

**Cutting action (fig. F)**

This jig saw is equipped with four cutting actions, three orbital and one straight. Orbital action has a more aggressive blade motion and is designed for cutting in soft materials like wood or plastic. Orbital action provides a faster cut, but with a less smooth cut across the material. In orbital action, the blade moves forward during the cutting stroke in addition to the up and down motion..

**Warning!** Metal or hardwoods should never be cut in orbital action.

- ◆ Move the cutting action lever (8) between the four cutting positions: 0, 1, 2, and 3..
- ◆ Position 0 is straight cutting.
- ◆ Positions 1, 2, and 3 are orbital cutting.
- ◆ The aggressiveness of the cut increases as the lever is adjusted from one to three, with three being the most aggressive cut.

**LED worklight**

The tool is equipped with an LED worklight (10) which projects on the cutting path.

- ◆ The LED worklight (10) will come on when the trigger switch (1) is pressed and will go off when the trigger switch (1) is released..

**Sawing**

- ◆ Always hold the tool with both hands.
- ◆ Let the blade run freely for a few seconds before starting the cut.
- ◆ Apply only a gentle pressure to the tool while performing the cut.

- ◆ If possible, work with the shoe plate (5) pressed against the workpiece. This will improve tool control and reduce tool vibration, as well as prevent the blade from being damaged.

**Hints for optimum use****General**

- ◆ Use a high speed for wood, a medium speed for aluminium and PVC and a low speed for metals other than aluminium.

**Sawing laminates**

As the saw blade cuts on the upward stroke, splintering may occur on the surface closest to the shoe plate.

- ◆ Use a fine-tooth saw blade.
- ◆ Saw from the back surface of the workpiece.
- ◆ To minimise splintering, clamp a piece of scrap wood or hardboard to both sides of the workpiece and saw through this sandwich.

**Sawing metal**

Be aware that sawing metal takes much more time than sawing wood.

- ◆ Use a saw blade suitable for sawing metal. Use a fine-tooth saw blade for ferrous metals and a coarser saw blade for non-ferrous metals.
- ◆ When cutting thin sheet metal, clamp a piece of scrap wood to the back surface of the workpiece and cut through this sandwich.
- ◆ Spread a film of oil along the intended line of cut.

**Accessories**

The performance of your tool depends on the accessory used. Stanley FaxMax accessories are engineered to high quality standards and designed to enhance the performance of your tool. By using these accessories you will get the very best from your tool.

This tool is suitable both for U-shank and T-shank saw blades.

**Maintenance**

Your tool has been designed to operate over a long period of time with a minimum of maintenance. Continuous satisfactory operation depends upon proper tool care and regular cleaning.

**Warning!** Before performing any maintenance, switch off and unplug the tool.

- ◆ Regularly clean the ventilation slots in your tool and charger using a soft brush or dry cloth.
- ◆ Regularly clean the motor housing using a damp cloth. Do not use any abrasive or solvent-based cleaner.
- ◆ Occasionally apply a drop of oil to the axle of the blade support roller.

## Protecting the environment



Separate collection. This product must not be disposed of with normal household waste.

Should you find one day that your Stanley FaxMax product needs replacement, or if it is of no further use to you, do not dispose of it with household waste. Make this product available for separate collection.



Separate collection of used products and packaging allows materials to be recycled and used again. Re-use of recycled materials helps prevent environmental pollution and reduces the demand for raw materials.

Local regulations may provide for separate collection of electrical products from the household, at municipal waste sites or by the retailer when you purchase a new product.

## Technical data

FME340 (Type 1)	
Input voltage	$V_{ac}$ 230
Power input	W 710
No-load speed	$min^{-1}$ 0 - 3,200
Stroke length	mm 20
Max depth of cut	
Wood	mm 85
Steel	mm 10
Aluminium	mm 15
Weight	kg 2.74

$L_{pA}$  (sound pressure) 90 dB(A), Uncertainty (K) 3 dB(A)

$L_{WA}$  (sound power) 101 dB(A), Uncertainty (K) 3 dB(A)

Vibration total values (triax vector sum) according to EN 60745:

Cutting boards ( $a_{h,B}$ ) 4.8  $m/s^2$ , uncertainty (K) 1.5  $m/s^2$

Cutting sheet metal ( $a_{h,M}$ ) 5.1  $m/s^2$ , uncertainty (K) 1.5  $m/s^2$

**Australia & New Zealand**

Stanley Black & Decker

82 Taryn Drive, Epping, VIC 3076 Australia

Tel. 1800 338 002 (Aust) or Tel. 0800 339 258 (NZ)