

 **BLACK & DECKER**

www.blackanddecker.com.au

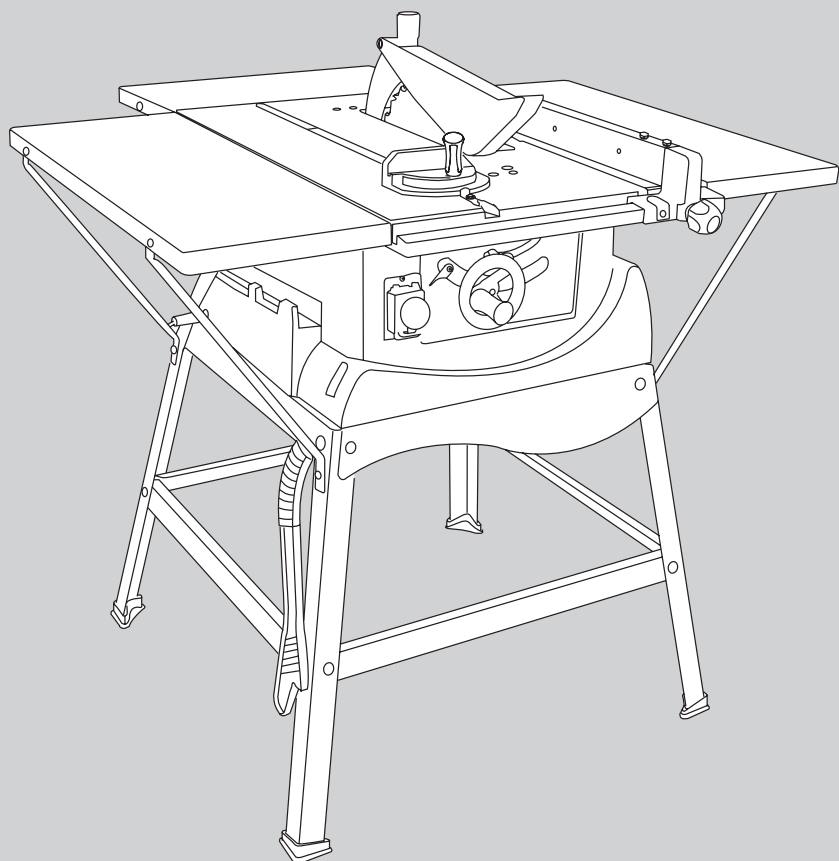

Australia

BT2504AE-XE

New Zealand

Fig. 1

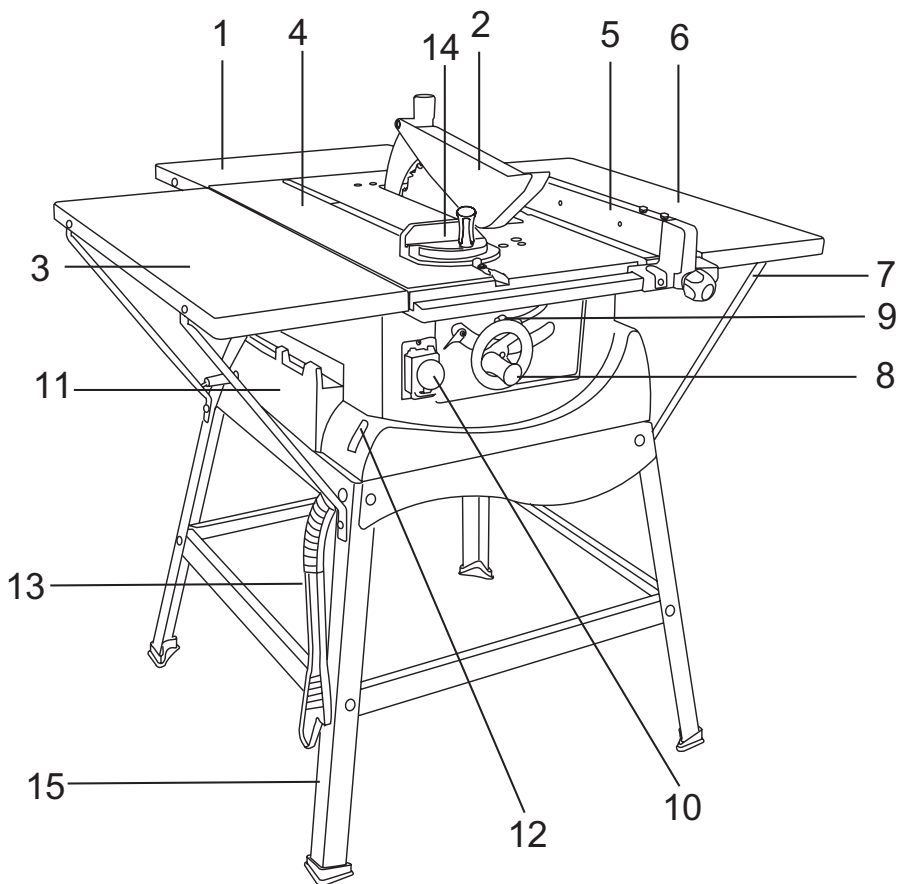

Know Your Table Saw (Fig. 1).

- | | |
|-------------------------------|--|
| 1. Rear table extension | 9. Saw blade tilt lock handle |
| 2. Upper blade guard | 10. No-Volt-Release (NVR) switch |
| 3. Left side table extension | 11. Rip fence & mitre gauge storage |
| 4. Main Table | 12. Mounting holes (tablesaw to stand) |
| 5. Rip fence | 13. Push-stick |
| 6. Right side table extension | 14. Mitre gauge |
| 7. Extension support | 15. Table saw stand |
| 8. Handwheel handle | |

Stand Assembly (Fig. 2)

1. Use the neck bolts (1), and nuts (2) to assemble the leg set parts.
2. Attach a leg (4) to the Upper Front support (5). Attach another leg to the opposite end. Tighten with neck bolt (1) and nut (2).
3. Attach Bottom Front support (7) between the legs. Finger tighten with neck bolt and nut.
4. Repeat this assembly for the remaining two legs, Upper Rear (3) and Bottom Rear support (7). Tighten with neck bolt and nut.
5. Insert the leg pag (6) into the leg.
6. Attach Upper Side support (8) and Bottom Side support (9) between the legs. Tighten with neck bolt and nut.
7. Place the leg set upright on a level service, adjust and tighten all nuts and bolts.

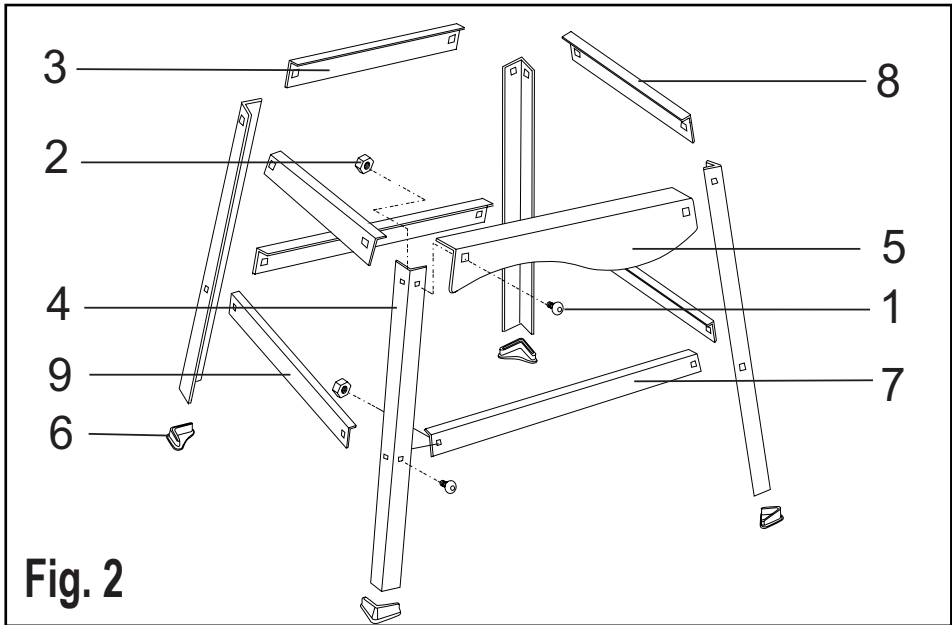
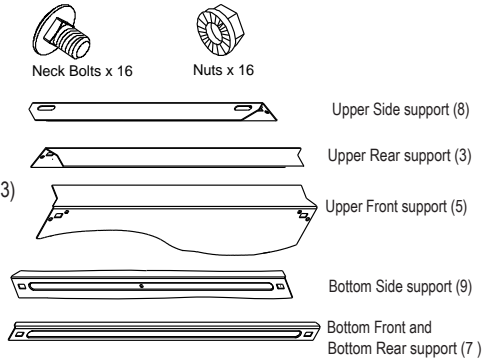

Assemble Base Cover To Table Saw

NOTE:Your saw is supplied with the base cover unassembled.

1. Assemble (1) to unit (2) using the 4 screws (3) supplied in bag.
2. Tighten the 4 screws (3) before mounting onto the stand.

Attach table saw unit to stand

1. Aligning the 4 holes (5) on table saw unit to stand.
2. Secure the connection using long hex bolt, washer and nuts.

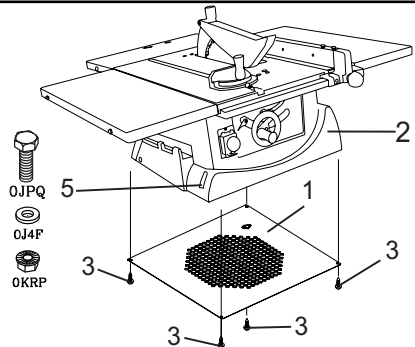

Extension Tables Assembly (Fig. 3)

PLEASE PAY ATTENTION TO THE DIFFERENT SIZE HEX BOLTS

| I.D. NO. | Description | Qty. |
|----------|---------------------------------|------|
| 0JRA | MEDIUM HEX. HD. BOLT | 6 |
| 22RP | MEDIUM HEX. NUT | 6 |
| 2JLB | REAR EXTENSION TABLE | 1 |
| 2BHF | REAR RETAINING CLIP | 2 |
| 3C5Z | RED KNOB | 12 |
| 0JQX | SMALL HEX. HD. BOLT | 4 |
| 0KJJ | ROUND CAP HD. SQ. NECK BOLT | 8 |
| 2BHD | EXTENSION TABLE | 2 |
| 2CAG | REAR SUPPORT ROD | 1 |
| 2CAH | LEFT SUPPORT ROD | 2 |
| 2CAJ | RIGHT SUPPORT RODS | 2 |
| 0JPQ | LARGE HEX. BOLT | 4 |
| 0J4F | FLAT WASHER | 4 |
| 0KRR | SERRATED TOOTHED HEX FLANGE NUT | 4 |

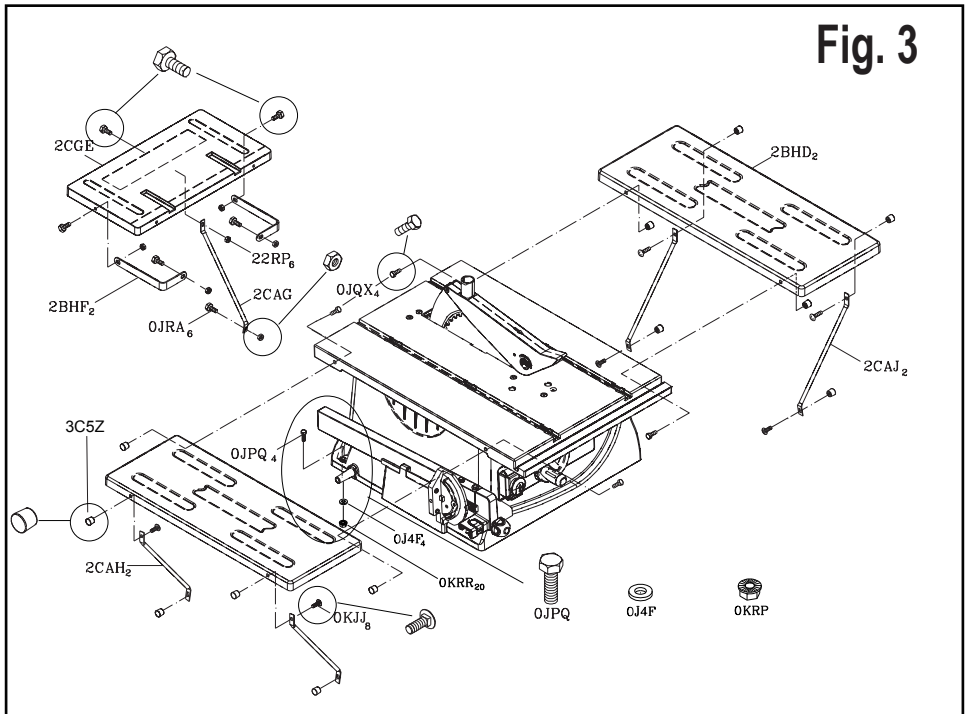

NUTS AND BOLTS REQUIRED FOR THIS ASSEMBLE



3C5Z
X 12



0JRA
X 6



22RP
X 6



0JQX
X 4



0KJJ
X 8



0JPQ
X 4



0J4F
X 4



0KRR
X 4

Intended use

Your Black & Decker Table saw has been designed for the four main sawing operations of ripping, cross-cutting, beveling and mitring easily, accurately and safely in wood and wood products.

This tool is intended for consumer use only.

Safety instructions

General power tool safety warnings



Warning! To reduce the risk of injury, the user must read the instruction manual.



Warning! Read all safety warnings and all instructions. Failure to follow the warnings and instructions listed below may result in electric shock, fire and/or serious injury.

Save all warnings and instructions for future reference.

The term "power tool" in the warnings refers to your mains operated (corded) power tool or battery operated (cordless) power tool.

1. Work area safety

- Keep work area clean and well lit.** Cluttered or dark areas invite accidents.
- Do not operate power tools in explosive atmospheres, such as in the presence of flammable liquids, gases or dust.** Power tools create sparks which may ignite the dust or fumes.
- Keep children and bystanders away while operating a power tool.** Distractions can cause you to lose control.

2. Electrical safety

- Power tool plugs must match the outlet. Never modify the plug in any way. Do not use any adapter plugs with earthed (grounded) power tools.** Unmodified plugs and matching outlets will reduce risk of electric shock.
- Avoid body contact with earthed or grounded surfaces such as pipes, radiators, ranges and refrigerators.** There is an increased risk of electric shock if your body is earthed or grounded.
- Do not expose power tools to rain or wet conditions.** Water entering a power tool will increase the risk of electric shock.
- Do not abuse the cord. Never use the cord for carrying, pulling or unplugging the power tool. Keep cord away from heat, oil, sharp edges or moving parts.** Damaged or entangled cords increase the risk of electric shock.
- When operating a power tool outdoors, use an**

extension cord suitable for outdoor use. Use of a cord suitable for outdoor use reduces the risk of electric shock.

- If operating a power tool in a damp location is unavoidable, use a residual current device (RCD) protected supply.** Use of an RCD reduces the risk of electric shock.
- Personal safety**
 - Stay alert, watch what you are doing and use common sense when operating a power tool. Do not use a power tool while you are tired or under the influence of drugs, alcohol or medication.** A moment of inattention while operating power tools may result in serious personal injury.
 - Use personal protective equipment. Always wear eye protection.** Protective equipment such as dust mask, non-skid safety shoes, hard hat, or hearing protection used for appropriate conditions will reduce personal injuries.
 - Prevent unintentional starting. Ensure the switch is in the off-position before connecting to power source and/or battery pack, picking up or carrying the tool.** Carrying power tools with your finger on the switch or energising power tools that have the switch on invites accidents.
 - Remove any adjusting key or wrench before turning the power tool on.** A wrench or a key left attached to a rotating part of the power tool may result in personal injury.
 - Do not overreach. Keep proper footing and balance at all times.** This enables better control of the power tool in unexpected situations.
 - Dress properly. Do not wear loose clothing or jewellery. Keep your hair, clothing and gloves away from moving parts.** Loose clothes, jewellery or long hair can be caught in moving parts.
 - If devices are provided for the connection of dust extraction and collection facilities, ensure these are connected and properly used.** Use of dust collection can reduce dust-related hazards.
 - Power tool use and care**
 - Do not force the power tool. Use the correct power tool for your application.** The correct power tool will do the job better and safer at the rate for which it was designed.
 - Do not use the power tool if the switch does not turn it on and off.** Any power tool that cannot be controlled with the switch is dangerous and must be repaired.
 - Disconnect the plug from the power source and/or the battery pack from the power tool before making any adjustments, changing accessories, or storing power tools.** Such preventive safety measures reduce the risk of

starting the power tool accidentally.

- d. **Store idle power tools out of the reach of children and do not allow persons unfamiliar with the power tool or these instructions to operate the power tool.** Power tools are dangerous in the hands of untrained users.
- e. **Maintain power tools. Check for misalignment or binding of moving parts, breakage of parts and any other condition that may affect the power tools operation. If damaged, have the power tool repaired before use.** Many accidents are caused by poorly maintained power tools.
- f. **Keep cutting tools sharp and clean.** Properly maintained cutting tools with sharp cutting edges are less likely to bind and are easier to control.
- g. **Use the power tool, accessories and tool bits etc. in accordance with these instructions, taking into account the working conditions and the work to be performed.** Use of the power tool for operations different from those intended could result in a hazardous situation.

5. Service

- a. **Have your power tool serviced by a qualified repair person using only identical replacement parts.** This will ensure that the safety of the power tool is maintained.
- b. **Power to the tool should always be supplied via residual current device with a rated residual current of 30mA or less.**

Additional Safety Instructions For Australia And New Zealand

- a. This appliance is not intended for use by person (including children) with reduced physical, sensory or mental capabilities or lack of experience and knowledge, unless they have been given supervision or instruction concerning use of the appliance by a person responsible for their safety. Children should be supervised to ensure that they don't play with the appliance.
- b. **Replacement of the supply cord.** If the supply cord is damaged, it must be replaced by the manufacturer or an authorised Black & Decker Service Centre in order to avoid a hazard.

Safety Instructions For All Saws



DANGER: Keep hands away from cutting area and the blade.

- a. **Do not reach underneath the workpiece.** The guard cannot protect you from the blade below the workpiece.
- b. **Adjust the cutting depth to the thickness of the workpiece.** Less than a full tooth of the blade teeth should be visible below the workpiece.

- c. **Always use blades with correct size and shape (diamond versus round) of arbour holes.** Blades that do not match the mounting hardware of the saw will run eccentrically, causing loss of control.
- d. **Never use damaged or incorrect blade washers or bolt.** The blade washers and bolt were specially designed for your saw, for optimum performance and safety of operation.
- e. **Consider work area environment.** Do not expose tools to rain. Do not use tools in damp or wet locations. Keep work area well lit. Do not use tools in the presence of flammable liquids or gases.
- f. **Guard against electric shock.** Avoid body contact with earthed or grounded surfaces.
- g. **Keep other people away.** Do not let others, especially children, not involved in the work touch the tool or the extension lead and keep them away from the work area.
- h. **Dress properly.** Do not wear loose clothing or jewellery, they can be caught in moving parts. Non-skid footwear is recommended when working outdoors. Wear protective hair covering to contain long hair.
- i. **Use protective equipment.** Use safety glasses. Use face or dust mask if cutting operations create dust.
- j. **Connect dust extraction equipment.** If devices are provided for the connection of dust extraction and collecting equipment, ensure these are connected and properly used.
- k. **Do not abuse the cable.** Never pull the cable to disconnect it from the socket. Keep the cord away from heat, oil and sharp edge.
- l. **Secure work.** Where possible use clamps or a vise to hold the work. It's safer than using your hand.
- m. **Don't overreach.** Keep proper footing and balance at all time.
- n. **Maintain tools with care.** Keep cutting tools sharp and clean for better and safer performance. Follow instructions for lubricating and changing accessories. Inspect tool cords periodically and if damaged have them repaired by an authorized service facility. Inspect extension cords periodically and replace if damaged. Keep handles dry, clean and free from oil and grease.
- o. **Disconnect tools.** When not in use, before servicing and when changing accessories such as blades, bits, cutters, disconnect tools from the power supply.
- p. **Remove adjusting keys and wrenches.** Form the habit of checking to see that keys and adjusting wrenches are removed from the tool before turning it on.
- q. **Avoid unintentional starting.** Ensure switch is in "off" position when plugging in.
- r. **Use outdoor extension leads.** When the tool is used outdoors, use only extension leads intended for outdoor use and so marked.

Additional Safety instructions for Table Saw



Warning! The use of any accessory or attachment, other than recommended in this instruction manual, may present a risk of personal injury.

- ◆ Do not use saw blades which are damaged or deformed.
- ◆ Do not use saw blades made from High Speed Steel.
- ◆ Do not use saw blades which do not comply with the characteristics specified within this manual.
- ◆ Do not stop the saw with lateral pressure on the blade.
- ◆ Do not lock the moveable guard in the open position.
- ◆ Ensure the moveable guard operates freely without jamming.
- ◆ Always remove the plug of the saw from the mains supply before making any adjustments or maintenance to the saw.
- ◆ Replace the table insert when worn.
- ◆ Use only saw blades recommended by the manufacturer which confirms to EN847-1, with warning that the riving knife shall not be thicker than the width of the groove cut by the saw blade and not thinner than the body of the saw blade.
- ◆ Take care that the selection of the saw blade depends on the material to be cut.
- ◆ Use push-sticks to feed the workpiece past the saw blade. The push-stick or push block should always be stored with the machine when not in use.
- ◆ Connect your table saw to a dust collecting device when sawing.
- ◆ Use and correct adjustment of the riving knife.
- ◆ Use and correct adjustment of the upper saw blade guard.
- ◆ Wear ear protection.
- ◆ Take care when slotting.
- ◆ Not for cutting metal, timber or round log.

Additional Safety Instructions For All Saws With Riving Knife

- a. **Use the appropriate riving knife for the blade being used.** For the riving knife to work, it must be thicker than the body of the blade but thinner than the tooth set of the blade.
- b. **Adjust the riving knife as described in this instruction manual.** Incorrect spacing, positioning and alignment can make the riving knife ineffective in preventing kickback.
- c. **Always use the riving knife except when plunge cutting.** Riving knife must be replaced after plunge cutting. Riving knife caused interference during plunge cutting and can create kickback.
- d. **For the riving knife to work, it must be engaged in the**

workpiece. The riving knife is ineffective in preventing kickback during short cuts.

- e. **Do not operate the saw if riving knife is bent.** Even a light interference can slow the closing rate of a guard.

SYMBOLS

| | |
|---|-----------------------------|
| V.....volts | A.....amperes |
| Hz.....hertz | W.....watts |
| min.....minutes | ~.....alternation current |
| h.....hours | ☐.....Class II Construction |
| I.....ON | O.....OFF |
| min ⁻¹revolutions per minute | |



- Wear safety goggles
- Wear ear protection
- Wear a breathing mask.



Symbol for transportation position

Specifications

MOTOR

| | |
|--------------------|--------------------------------|
| Type | Series commutator motor |
| Power source | Single-phase AC 50 Hz |
| Voltage..... | 220~240V, 1700 W S6 25% 10 min |
| Insulation..... | Class II ☐ |

BLADE

| | |
|----------------------------|--------------------------------------|
| Type..... | Tungsten Carbide Tipped 24T |
| Dimension..... | Outside Dia. 250 mm, Bore Dia. 30 mm |
| No Load Speed..... | 4800 min ⁻¹ |
| Blade Tilt..... | 0°~45° Left |
| Max. Cutting Capacity..... | 73 mm at 90°, 63 mm at 45° |
| Table Size | 640 x470 mm |
| Net Weight..... | 24.65 kg |

WARNING! Noise can be a health hazard. When the noise level exceeds 85 dB(A), be sure to wear ear protection.

The noise level of this machine during cutting are as follows:

| | |
|-----------------------|--------------|
| Sound pressure level: | 91.6 dB (A) |
| Sound power level: | 104.6 dB (A) |

Through poor conditions of the electrical MAINS, shortly voltage drops can appear when starting the EQUIPMENT. This can influence other equipment (e.g. blinking of a lamp)

Assembly

WARNING! For your own safety, never connect the plug to power source outlet until all assembly steps are completed and you have read and understood the safety and operational instructions.



NOTE: Move all parts to the desired work site before assembling them together. Follow the assembly instruction and carefully assemble the tool with the help of a second person.

INSTALLING

INSTALLING REAR TABLE EXTENSION (FIG. A)

1. Place L bracket (5) under rear table extension (3) tighten using medium hex bolt (2) and nut (1).
2. Place the rear table extension (3) next to the table saw, aligning the mounting holes (4).
3. Insert the hex bolt (2) through the bracket (5), secure rear extension (3) into the mounting hole (4) tighten using medium hex nut (1).
4. Attach the other end of the rear table extension to the table saw using same method.
5. Place the extension supports (7) to the rear table extension, secure both end with bolts(2) and nuts(1).

Fig. A

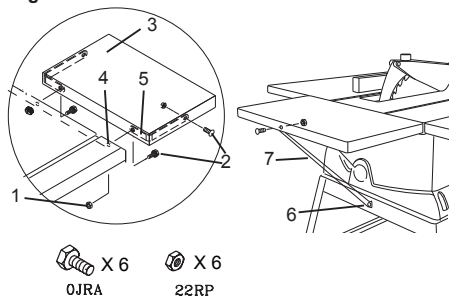

INSTALLING TABLE SIDE EXTENSION (FIG. B)

1. Place the left table extension next to the saw table, aligning the mounting holes (1).
2. Insert the small hex bolts (3) through the mounting holes(1) and tighten using red knob (2).
3. Repeat setp 2 for another end.
4. Adjust the knob (2) until the extension is flush with the saw table. Tighten.
5. Place the extension supports (4) to the left table extension and secure them on the stand with round cap bolts (5) and red knob (2)
6. Repeat these procedures for the right extension table.

Fig. B

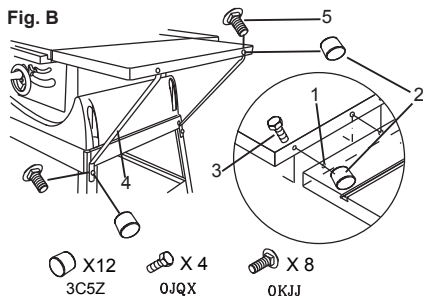

INSTALLING OR CHANGING THE BLADE (FIG. C, C1)

⚠ WARNING

To avoid injury from accidental starting, always turn the switch off ("0") and remove the power plug from the power source before changing the blades.

Always wear gloves when changing the blades.

1. Loosen the screws (3) on the table insert by a screwdriver and remove the table insert.
2. Loosen the screw (4) on the plate by a screwdriver and remove the plate (5).

Fig. C

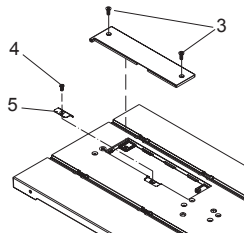

3. Raise the saw blade to its maximum height by rotate the handwheel anticlockwise.
4. Use the supplied open end wrench (1) to keep the arbor from turning and the supplied box-end wrench (2) to loosen the arbor nut (4). (Fig. C1)
5. Remove the arbor nut (4) and outer flange (3).
6. Replace the saw blade(5). Make sure the teeth of the blade point down at the front of the table.
7. Assemble the outer flange and arbor nut back to the saw arbor and finger tighten the arbor nut.
8. Further tighten the arbor nut (4) using open end wrench (1) and box-end wrench (2). (Fig.C2)

Fig. C1

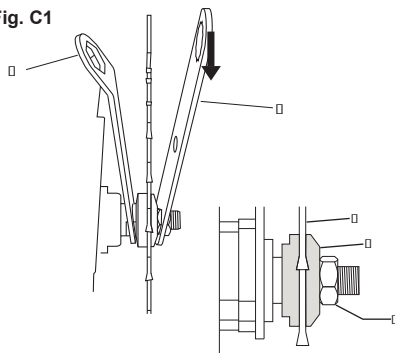
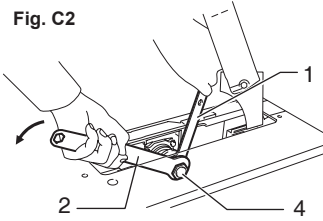

Fig. C2

**INSTALLING THE RIVING KNIFE (FIG. D)**

1. Rise the blade to its highest position by turning the handwheel and tilt the blade to 45° bevel angle.
2. Loosen the screws on the table insert and remove the table insert.
3. Place the knob bolts (3), and flat washers (4) on the riving knife bracket (5) and the riving knife (6).
4. Insert one supplied spacer (7) between the riving blade (6) and the bracket (5).
5. Tighten the knob bolts (3).
6. Replace the table insert and tighten the screw.

WARNING

The riving knife thickness of 2.5 mm. Make sure the blade and riving knife are aligned on the same line. If not, adjust the riving knife by loosening the knob bolts. Gap should be less than 5 mm at all positions.

Fig. D

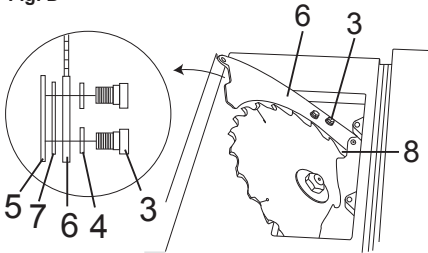
**Blade Guard Assembly (Fig. E)**

Place the blade guard on the riving knife and secure it with the bolt (1), flat washer (2), and nut (3).

Fig. E

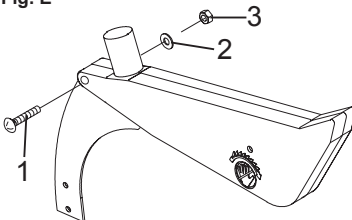
**ALIGNING THE RIVING KNIFE (FIG. F)**

1. If the blade and riving knife are not correctly aligned:
 - a. Remove the table insert by removing the screws.
 - b. Remove the blade guard by removing the bolt, flat washer and nut that lock the guard in place.
 - c. Loosen the two bolts (3) from the riving knife bracket (5).
2. Insert or remove the spacers (7) between the riving knife (6) and bracket (5).
3. Retighten the two mounting bolts (3) securely.
4. Replace the blade guard assembly using the bolt, flat washer and nut.
5. Check the riving knife and blade alignment again at both 90° and 45°.
6. Add or remove the spacers until the alignment is correct.
7. Replace the table insert.

Fig. F

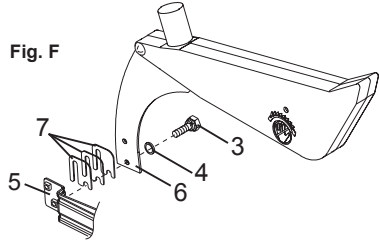
**INSTALLING THE RIP FENCE (FIG. G)**

Slide in the rip fence assembly from the end of the table with aligning the groove in the front of the table and the tongue on the fence bracket.

Fig. G

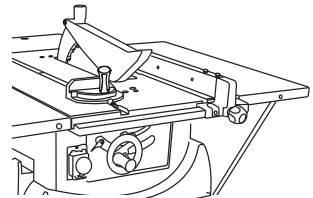

ADJUSTING

NOTE: This tool is pre-adjusted before shipping from the factory. Check the following accuracy and readjust them if necessary in order to obtain the best results in operation.

ADJUSTING THE BLADE PARALLEL TO THE MITRE GAUGE GROOVE (FIG. L, M, N)

WARNING

This adjustment must be correct or kickback could result and accurate cuts cannot be made.

1. Raise the blade to its highest position and set it to 0° bevel angle.
2. Select a tooth on the saw blade which is bent to the right. Mark that tooth with a pencil or permanent marker.
3. Place the mitre gauge (1) in the right hand groove (2) on the table top. Set the mitre gauge to 90° and tighten the gauge handle to lock it in that position.
4. Rotate the blade to bring the marked tooth in the front and about 13 mm above the table top. Place the bar of square (3) flat against the mitre gauge and move the bar toward the saw blade until it just touches the tip of the marked saw blade tooth. (Fig. L)

Fig. L

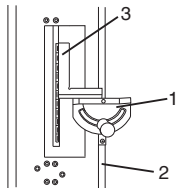

5. Without disturbing the bar clamped to the mitre gauge (1), move the mitre gauge to the centre of the saw blade. Rotate the blade so the marked tooth is at the rear and about 13 mm above the table top.
6. Slide the mitre gauge rearward until the clamped bar is closest to the tip of the marked tooth. (Fig. M)

Fig. M

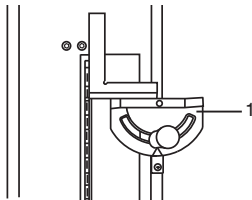

7. If the bar just touches the tooth when the gauge was in the front position, it should touch the tooth in the rear position.

8. If the front and rear clearance are not identical, remove the mitre gauge, loosen four screws (1) and carefully grasp the saw blade. Make necessary correction until measurements taken at the front and rear are identical. Tighten the four screws (1). (Fig. N)

Fig. N

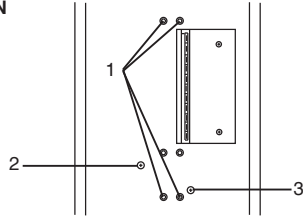

ADJUSTING 90° POSITIVE STOP OF BLADE

1. Raise the saw blade to its maximum height.
2. Loosen the saw blade tilt lock handle and move the saw blade tilting mechanism to the left until it hits against the stopper. Then tighten the saw blade tilt lock handle.
3. Use a square (1) to check the saw blade is at 90°. (Fig. O)
4. If the saw blade is not at 90°, loosen the saw blade tilt lock handle. Adjust the screws (2-Fig. N) a few turns and move the saw blade tilting mechanism until the blade is at 90° to the table.
5. Tighten the saw blade tilt lock handle after adjustment.
6. Loosen the screw of the tilt pointer and set the pointer to 0°.

Fig. O

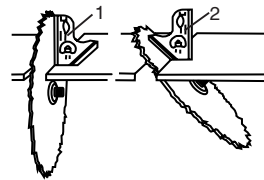

ADJUSTING 45° POSITIVE STOP OF BLADE

1. Raise the saw blade to its maximum height.
2. Loosen the saw blade tilt lock handle and move the saw blade tilting mechanism to the right until it hits against the stopper. Then tighten the saw blade tilt lock handle.
3. Use a 45° gauge (2) to check the saw blade is at 45°. (Fig. O)
4. If the saw blade is not at 45°, loosen the saw blade tilt lock handle. Adjust the screws (3-Fig. N) a few turns and move the saw blade tilting mechanism until the blade is at 45° to the table.
5. Tighten the saw blade tilt lock handle after adjustment.
6. Loosen the screw of the tilt pointer and set the pointer to 45°.

ADJUSTING RIP FENCE (FIG. P)**⚠ WARNING**

This adjustment must be correct or kickback could result and accurate cuts cannot be made.

1. Loosen the clamp handle (1).
2. Position the rip fence at one edge of the mitre gauge groove.
3. Lock the rip fence to the table using the clamp handle. The edge of the rip fence should then line up parallel with the mitre gauge groove.
4. If the edge of the rip fence is not parallel with the mitre gauge groove, loosen the bolts (2) on the fence, adjust the fence until it is parallel with the mitre gauge groove, then tighten the bolts (2).

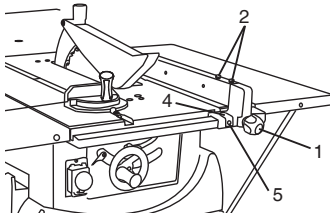
Fig. P**ADJUSTING THE POINTER OF RIP FENCE (FIG. P)**

NOTE: The pointer will need to be readjusted whenever a different thickness saw blade is installed.

1. To adjust pointer 0° setting, loosen the clamp handle (1) and move the rip fence to bring it into tight contact with the side of the saw blade.
2. Make sure that the pointer (4) points to 0° on the scale in the front of table.
3. If the pointer does not point to 0° on the scale, tighten the clamp handle, loosen the pointer screw (5) and adjust the pointer to the 0° position and retighten the pointer screw.

ADJUSTING THE MITRE GAUGE (FIG. Q)

1. To adjust pointer 90° setting, loosen the clamp handle (1) and place a square (2) against both the saw blade (3) and mitre gauge (4). The pointer (5) should indicate 90° on the mitre gauge.
2. If the pointer does not point to 90° on the mitre gauge, tighten the clamp handle, loosen the pointer screw (6) on the bar, adjust the pointer to the 90° position and retighten the pointer screw.

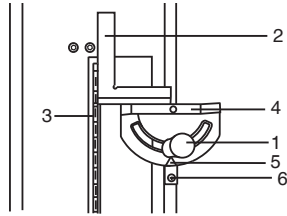
Fig. Q

OPERATION

SWITCHES OF THE TABLE SAW (FIG. R)

The main switch (3-Fig. R), No Volt Release (NVR) switch, is on the front of saw base. Press "I" to turn on the power; press "O" to turn off the power.

⚠ WARNING

Never connect the plug to the power source outlet until all installations and adjustments are completed and you have read and understood the safety and operational instructions.

RAISING AND LOWERING THE SAW BLADE (FIG. R)

⚠ WARNING

Never operate while saw blade rotating.

1. To raise the saw blade, rotate the handwheel (1) anticlockwise.
2. To lower the saw blade, rotate the handwheel (1) clockwise.

NOTE: The saw blade height is recommended about 3.2 mm above the top of the workpiece.

Fig. R

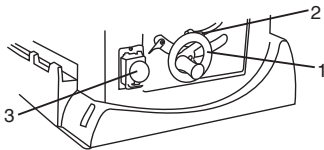

TILTING THE SAW BLADE (FIG. R)

⚠ WARNING

Always lock the saw blade tilt lock handle during operations.

Loosen the saw blade tilt lock handle (2), move the hand wheel until the saw blade is at the desired angle and tighten the saw blade tilt lock handle.

MOVING THE RIP FENCE

NOTE:

1. The rip fence can be used on either side of the saw blade.
2. The pointer on the rip fence indicates the distance between the saw blade and rip fence.
3. To move the rip fence, loosen the clamp handle while pressing the fence bracket against the table surface and set the desired distance from the saw blade, retighten the clamp handle.

OPERATING THE MITRE GAUGE

NOTE:

1. The mitre gauge can be used on either side of the saw blade.
2. Because the mitre gauge groove is a T-type slot, to install the mitre gauge, insert the gauge bar from the end of the groove.
3. To set the mitre cut angle, loosen the clamp handle, turn the mitre gauge to the desired angle, retighten the clamp handle.

RIPPING (FIG. S)

NOTE:

1. Generally ripping is cutting with the grain.
2. Do not perform ripping "free hand". Use the rip fence for ripping and remove the mitre gauge from the table.

⚠ WARNING

1. **Before ripping, confirm the following items:**
 - a. **Rip fence is securely fixed and parallel to the saw blade.**
 - b. **Riving knife is properly aligned with the saw blade.**
 - c. **The workpiece must have a straight edge against the rip fence and must not be warped, twisted or bowed.**
2. **Keep both hands away from the saw blade and away from the path of the saw blade.**

1. Adjust the saw blade height so it is about 3.2 mm above the top of the workpiece.
2. Hold the workpiece flat on the table and against the rip fence. Keep the workpiece about 25 mm away from the saw blade.
3. Turn on the switch and allow the saw blade to come up to speed.
4. Keep the workpiece against the table and rip fence, slowly feed the workpiece rearward all the way through the saw blade. Continuously push the workpiece until it passes the blade guard and clears the rear of the table.
5. When ripping long boards or large panels, always use an adequate support.
6. When the width of rip is more than 150 mm, feed the workpiece with one or both hands continuously until it is beyond the saw blade and riving knife

⚠ WARNING

Never operate while saw blade rotating.

7. When the width of rip 50 mm to 150 mm wide, use the supplied push stick to feed the workpiece.
8. When perform bevel ripping, only work with the work piece and rip fence on the right side of the saw blade.

Fig. S

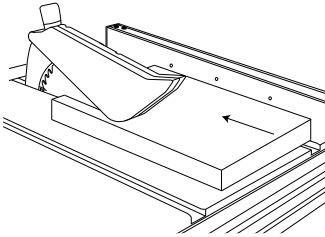
**CROSSCUTTING (FIG. T)**

NOTE:

1. Generally cross cutting is cutting across the grain.
2. Do not perform cross cutting "free hand". Use the mitre gauge for cross cutting and remove the rip fence from the table.

⚠ WARNING

1. **Before cross cutting, confirm the following items:**
 - a. **Riving knife is properly aligned with the saw blade.**
 - b. **The workpiece must have a straight edge against the mitre gauge and must not be warped, twisted or bowed.**
2. **Keep both hands away from the saw blade and away from the path of the saw blade.**

1. Adjust the saw blade height so it is about 3.2 mm above the top of the workpiece.
2. Hold the workpiece flat on the table and against the mitre gauge. Keep the workpiece about 25 mm away from the saw blade.
3. Turn on the switch and allow the saw blade (1) to come up to full speed.
4. Keep the workpiece (2) against the table and mitre gauge (3), slowly feed the workpiece rearward all the way through the saw blade. Continuously push the workpiece until it is clear of the blade guard and it falls off the rear of the table.

5. When performing bevel cross cutting, only work with the workpiece and mitre gauge on the right side of the saw blade.

Fig. T

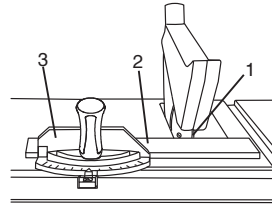
**BEVEL CROSSCUTTING (FIG. U)**

This cutting operation is the same as crosscutting except the blade is at bevel angle other than 0°.

⚠ WARNING

Always work to the right side of the blade during this type of cut. The mitre gauge (3) must be in the right side groove (2) because the bevel angle may cause the blade guard to interfere with the cut if used on the left side groove.

1. Adjust the blade (1) to the desired angle, and tighten the blade bevel lock knob.
2. Tighten mitre lock handle at 90°.
3. Hold workpiece firmly against the face of the mitre gauge (3) throughout the cutting operation.

NOTE: When tilting the blade to 45°, the mitre gauge handle will hit the blade guard.

Fig. U

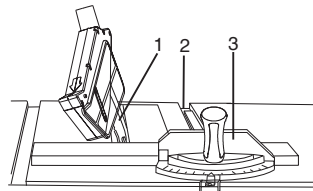

COMPOUND MITRE CROSSCUTTING (FIG. V)

This sawing operation is combining a mitre angle with a bevel angle.

⚠ WARNING

Always work to the right side of the blade during this type of cut. The mitre gauge (3) must be in the right side groove because the bevel angle may cause the blade guard to interfere with the cut if used on the left side groove. When tilting the workpiece to 45° and push it toward the blade, the blade guard may hit the blade. To avoid injury, stop the work at that time.

1. Set the mitre gauge (3) to the desired angle.
2. Place the mitre gauge (3) in the right side groove (2) of the table.
3. Set the blade (1) bevel to the desired bevel angle and tighten the blade bevel lock knob.
4. Hold workpiece firmly against the face of the mitre gauge (3) throughout the cutting operation.

Fig. V

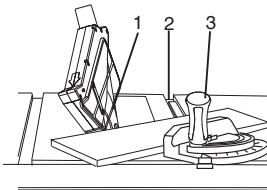

MITRE CUTS (FIG. W)

This sawing operation is the same as crosscutting except the mitre gauge is locked at an angle other than 90°.

1. Set the blade (1) to 0° bevel angle and tighten the blade bevel lock knob.
2. Set the mitre gauge (3) at the desired mitre angle and lock in position by tightening the mitre gauge locking handle.
3. Hold the workpiece (2) firmly against the face of the mitre gauge throughout the cutting operation.

Fig. W

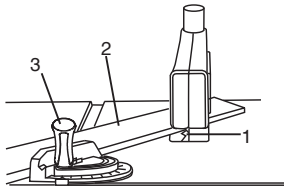

USING THE DUST PORT (FIG. X)

⚠ WARNING

To prevent fire hazard, clean and remove sawdust from under the saw frequently.

To prevent sawdust build up inside the saw housing, attach a vacuum hose (1) to the dust port (2) at the rear of the table saw. DO NOT operate the saw with the hose in place unless the vacuum is turned on.

Fig. X

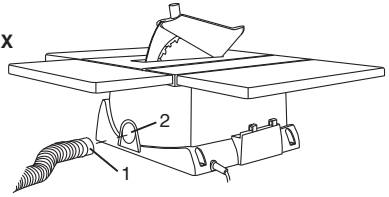

USING THE STORAGE BRACKET (FIG. Y)



Hanging hook for push stick



Storage bracket for extension tables when it is not been used

Fig. Y

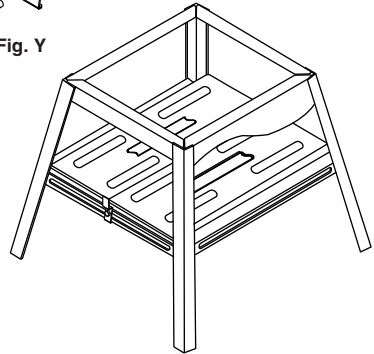

Maintenance

Warning! For your own safety, turn the switch off and remove the plug from the power source outlet before maintaining or lubricating your table saw.

General Maintenance

Occasionally use a cloth to wipe off chips and dust from the machine. And oil the rotary parts once a month to extend the tool life. Do not oil the motor.

Brush Inspection

Check the motor brushes after the first 50 hours of use for a new machine or after a new set of brushes have been installed. After the first check, examine them every 10 hours of use.

When the carbon is worn to 0.2 mm in length or if the spring or shunt wire is burned or damaged, replace both brushes. If the brushes are found serviceable after removing, reinstall them.

ENVIRONMENTAL PROTECTION



Recycle unwanted materials instead of disposing of them as waste. All tools, hoses and packaging should be sorted, taken to the local recycling center and disposed of in an environmentally safe way.

BT2504AE PARTS LIST

| I.D. NO. | Description | Size | Qty. | I.D. NO. | Description | Size | Qty. |
|----------|---------------------------------|--------------|------|----------|-------------------------------------|----------------|------|
| 0BV4 | RUBBER | | 1 | 0KMV | HEX. NUT | M10*1.5 T=8 | 1 |
| 0BVH | CORD CLAMP | | 1 | 0KMW | HEX. NUT | M10*1.5 T=4 | 1 |
| 09JK | BOX END WRENCH | | 1 | 0KMY | HEX. NUT | M8*1.25 T=6.5 | 1 |
| 0B22 | HEIGHT REGULATING BOLT | | 1 | 0KQJ | CROWN NUT | M8*1.25 T=12.5 | 1 |
| 0B23 | SADDLE | | 1 | 0KRQ | SERRATED TOOTHED HEXAGON FLANGE NUT | M6*1.0 T=6 | 7 |
| 0B24 | SPRING | | 1 | 0KRX | HEXAGON NUT AND FLAT WASHER | M6*1.0 | 1 |
| 0B25 | POINTER BRACKET | | 1 | 0KT5 | GUARD-CORD | | 1 |
| 0B3R | OPEN END WRENCH | | 1 | 0KTD | STRAIN RELIEF | | 2 |
| 0B99 | SPACER | | 1 | 0LN4 | WIRE CONNECTOR | | 1 |
| 0B9C | PLUNGER HOUSING | | 1 | 0LVP | FERRITE CORE | | 1 |
| 0B9M | STRAP | | 6 | 0M0H | CAPACITOR | | 1 |
| 0B9W | BRACKET | | 1 | 26BN | CR. RE. PAN HD. SCREW | M6*1.0-25 | 1 |
| 0B9W | BRACKET | | 1 | 2B7H | RETAINING CLIP | | 1 |
| 0BA4 | SPACER | | 1 | 28GK | ARBOR COLLAR | | 1 |
| 0BAC | SET NUT | | 1 | 28GV | ANGLE ROD | | 1 |
| 0HDL | DUST TUBE | | 1 | 28KD | TILT POINTER | | 1 |
| 0J4F | FLAT WASHER | φ8*16-2.5 | 1 | 28XZ | COVER | | 1 |
| 0J4H | FLAT WASHER | φ10*30-0.2 | 2 | 290X | LEAD WIRE ASS'Y | | 1 |
| 0J70 | FLAT WASHER | 1/4*3/4-7/64 | 2 | 290Y | LEAD WIRE ASS'Y | | 1 |
| 0J72 | FLAT WASHER | 1/4*5/8-1/16 | 1 | 29KV | C-RING | | 1 |
| 0J8D | FLAT WASHER | 3/8*3/4-5/64 | 2 | 2BH9 | SPLITTER | | 1 |
| 0J8K | FLAT WASHER | 1/4*3/4-1/16 | 2 | 2BHA | SPLITTER BRACKET | | 1 |
| 0J9H | SPRING WASHER | φ1/4" | 6 | 2BHB | LEVER | | 1 |
| 0JCA | SPRING PIN | | 1 | 2BJJ | TABLE | | 1 |
| 0JFC | SELF-LOCKING RING | | 2 | 2BJX | DUST COLLECTOR | | 1 |
| 0JXL | HEX. SOC. SET SCREW | M10*1.5-12 | 1 | 2BKT | TRIGGER VALVE SEAT | | 1 |
| 0JYN | HEX. SOC. COUNTERSUNK HD. SCREW | M6*1.0-25 | 6 | 2BKU | DUST GUARD | | 1 |
| 0K0Z | HEX. HD. SCREW AND WASHER | | 4 | 2BKV | FLOOR PLATE | | 1 |
| 0K16 | HEX. HD. SCREW AND WASHER | M8*1.25-16 | 1 | 2BKX | CONNECTOR | | 1 |
| 0K1J | HEX. HD. SCREW AND WASHER | | 2 | 3C7Z | BLADE GAUGE ASS'Y | | 1 |
| 0K25 | HEX. SOC. HD. CAP SCREW | M5*0.8-20 | 1 | 3C80 | MITER GAUGE ASS'Y | | 1 |
| 0K3G | CR. RE. PAN HD. SCREW & WASHER | M5*0.8-12 | 1 | 3CH7 | BLADE | | 1 |
| 0K8C | CR. RE. COUNT HD. TAPPING SCREW | M4*18-10 | 7 | 3CSU | PUSH BLOCK | | 1 |
| 0KA4 | CR. RE. PAN HD. TAPPING SCREW | M4*16-16 | 2 | 2CBT | HAND WHEEL ASS'Y | | 1 |
| 0KA5 | CR. RE. PAN HD. TAPPING SCREW | M4*16-20 | 2 | 3C7R | PARALLEL BRACKET ASS'Y | | 1 |
| 0KA6 | CR. RE. PAN HD. TAPPING SCREW | M5*12-10 | 3 | 3C9C | PUSH BUTTON SWITCH ASS'Y | | 1 |
| 0KDM | CR. RE. PAN HD. SCREW | M5*0.8-20 | 4 | 3CH5 | SCALE | | 1 |
| 0KDR | CR. RE. PAN HD. SCREW | M5*0.8-10 | 1 | 3C5V | LOCK KNOB | | 1 |
| 0KJ0 | CAP HD. SQ. NECK BOLT | M6*1.0-16 | 1 | 3C5T | BODY SHELL | | 1 |
| 0KJ4 | CAP HD. SQ. NECK BOLT | M6*1.0-35 | 1 | 3CH3 | LABEL | | 1 |
| 0KJ5 | CAP HD. SQ. NECK BOLT | M6*1.0-80 | 1 | Y4KF | POWER CABLE | | 1 |
| 0KM2 | RIVET | | 2 | 259G | LEVER BRACKET | | 1 |
| 0KMR | HEX. NUT | M5*0.8 T=4 | 1 | 2WD2 | MOTOR | | 1 |
| 0KMS | HEX. NUT | M6*1.0 T=5 | 1 | | | | |

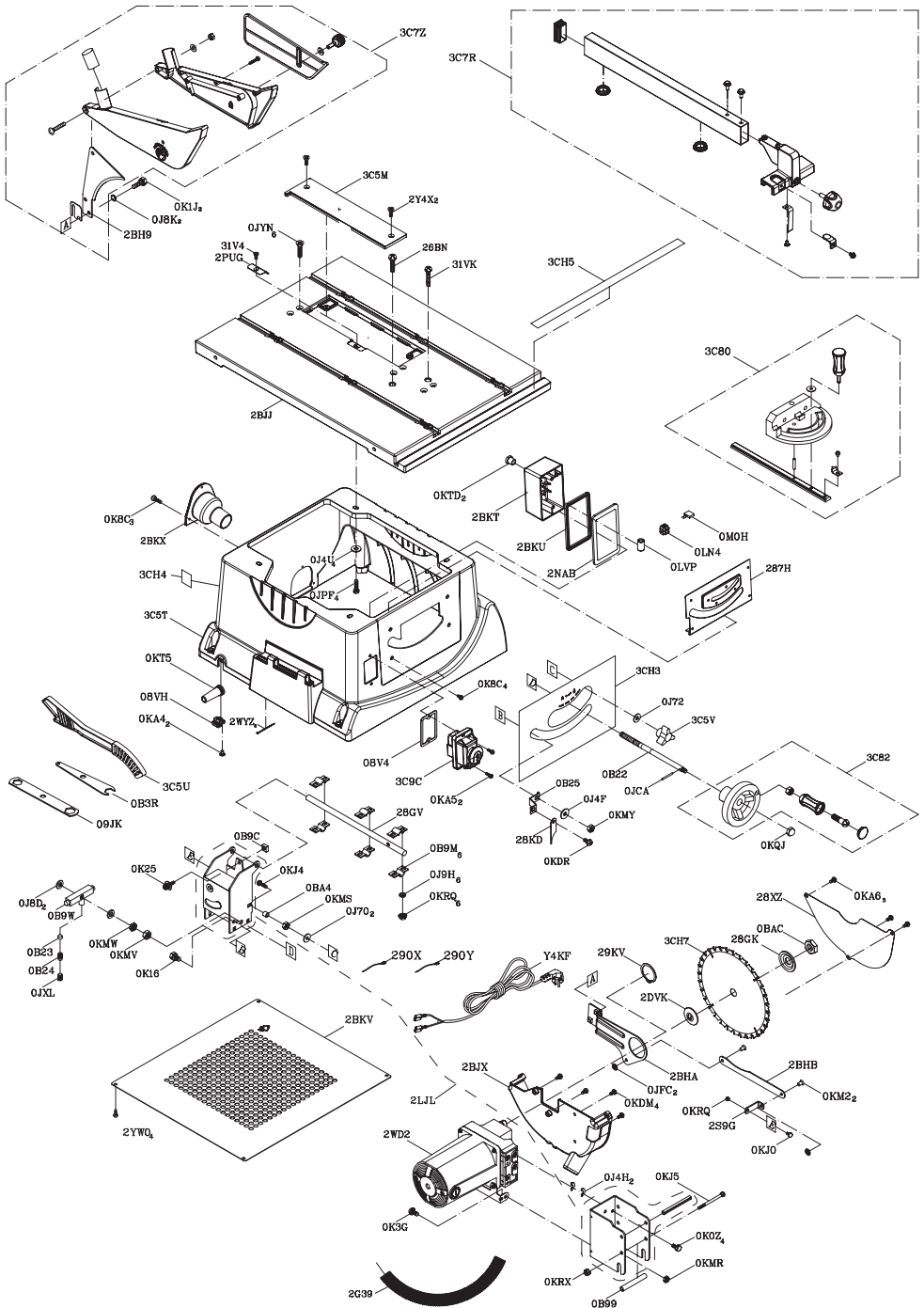

BT2504AE MOTOR PARTS LIST

| I.D. NO. | Description | Size | Qty. |
|----------|--|------------|------|
| 0HX9 | NEEDLE BEARING | HK-1010 | 1 |
| 0JAL | EXT. TOOTH LOCK WASHER | φ4 | 3 |
| 0JX3 | HEX. SOC. SET SCREW | M5*0.8-8 | 2 |
| 0K52 | CR. RE. COUNT HD. SCREW | M4*0.7-12 | 3 |
| OKTD | STRAIN RELIEF | | 1 |
| 0QM2 | BRUSH HOLDER ASS'Y | | 2 |
| 0QQU | CARBON BRUSH ASS'Y | | 2 |
| 0QR0 | BRUSH COVER | | 2 |
| 110A | CR. RE. PAN HD. TAPPING SCREW & WASHER | M5* 12-55 | 2 |
| 2DW9 | WAVE WASHER | | 1 |
| 2RPP | FLOW GUIDE | | 1 |
| 32EE | CR. RE. PAN HD. SCREW & WASHER | M5* 0.8-50 | 4 |
| 2WDK | MOTOR COVER | | 1 |
| 2WD4 | FIELD ASS'Y | | 1 |
| 2WDD | ARMATURE ASS'Y | | 1 |
| 3CCS | CUTTER SHAFT ASS'Y | | 1 |
| 2WDE | BRACKET | | 1 |
| 2WDY | LABEL | | 1 |

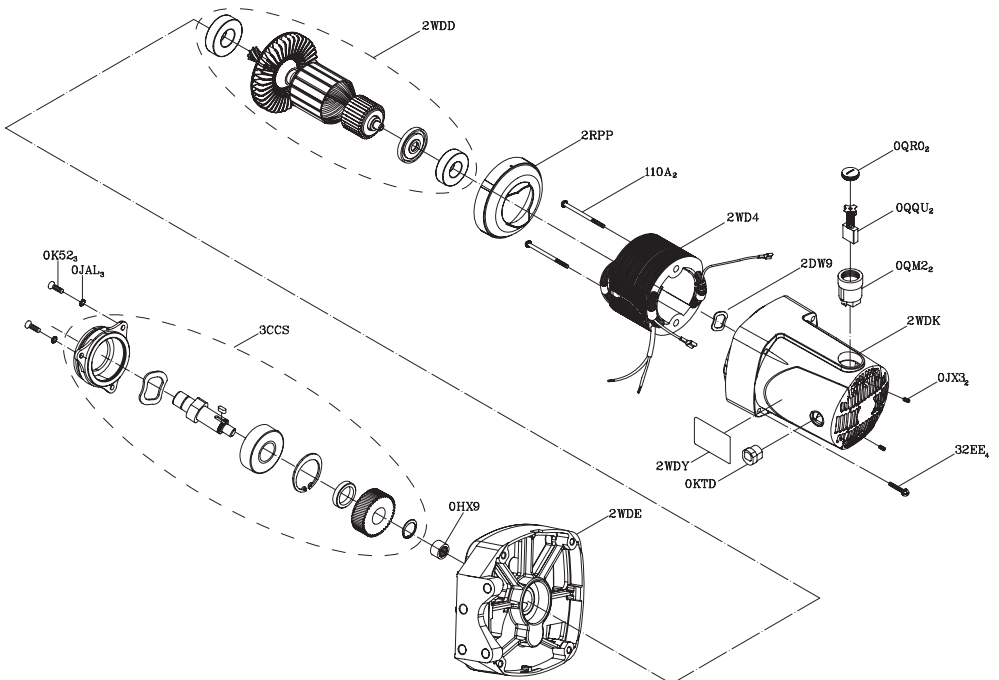

BT2504AE STAND ASSEMBLE GUIDE

| I.D. NO. | Description | Qty. |
|----------|-------------------------------------|------|
| 0KJ7 | BLACK LARGE CAP HD. SQ.NECK BOLT | 16 |
| 0KRR | SERRATED TOOTHED HEXAGON FLANGE NUT | 20 |
| 2CAK | BOTTOM FRONT&REAR SUPPORT | 2 |
| 2CAL | BOTTOM SIDE SUPPORT | 2 |
| 3C7X | FRONT UPPER SUPPORT | 1 |
| 2CAN | REAR UPPER SUPPORT | 1 |
| 2CAP | SIDE UPPER SUPPORT | 2 |
| 2CAQ | LEG SUPPORT | 4 |
| 3C5Y | LEG PAD | 4 |
| 2CCQ | PUSH STICKER HOOK | 1 |
| 2CHL | SIDE HOOK | 2 |
| 0KMS | HEX. NUT | 2 |
| 0JPC | HEX. HD. BOLT | 2 |

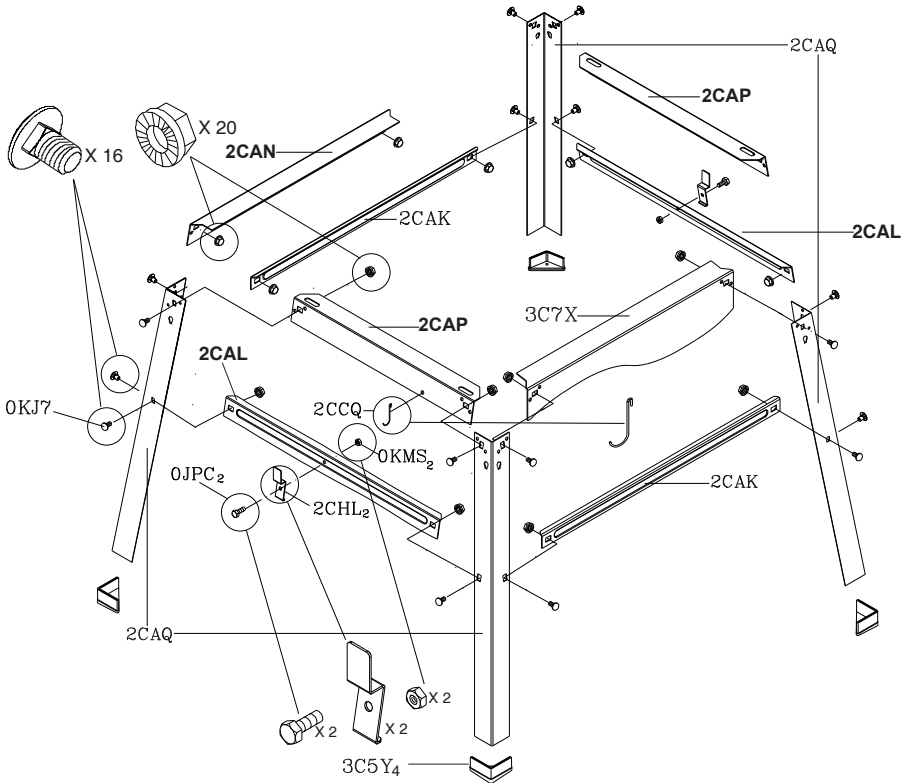

BT2504AE EXTENSION TABLE ASSEMBLE

PLEASE PAY ATTENTION TO THE DIFFERENT SIZE HEX BOLTS

| I.D. NO. | Description | Qty. |
|----------|---------------------------------|------|
| 0JRA | MEDIUM HEX. HD. BOLT | 6 |
| 22RP | MEDIUM HEX. NUT | 6 |
| 2CGE | REAR EXTENSION TABLE | 1 |
| 2BHF | REAR RETAINING CLIP | 2 |
| 3CSZ | RED KNOB | 12 |
| 0JQX | SMALL HEX. HD. BOLT | 4 |
| 0KJJ | ROUND CAP HD. SQ. NECK BOLT | 8 |
| 2BHD | EXTENSION TABLE | 2 |
| 2CAG | REAR SUPPORT ROD | 1 |
| 2CAH | LEFT SUPPORT ROD | 2 |
| 2CAJ | RIGHT SUPPORT RODS | 2 |
| 0JPQ | LARGE HEX. BOLT | 4 |
| 0J4F | FLAT WASHER | 4 |
| 0KRR | SERRATED TOOTHED HEX FLANGE NUT | 4 |
| 3CH6 | STICKERS | 2 |

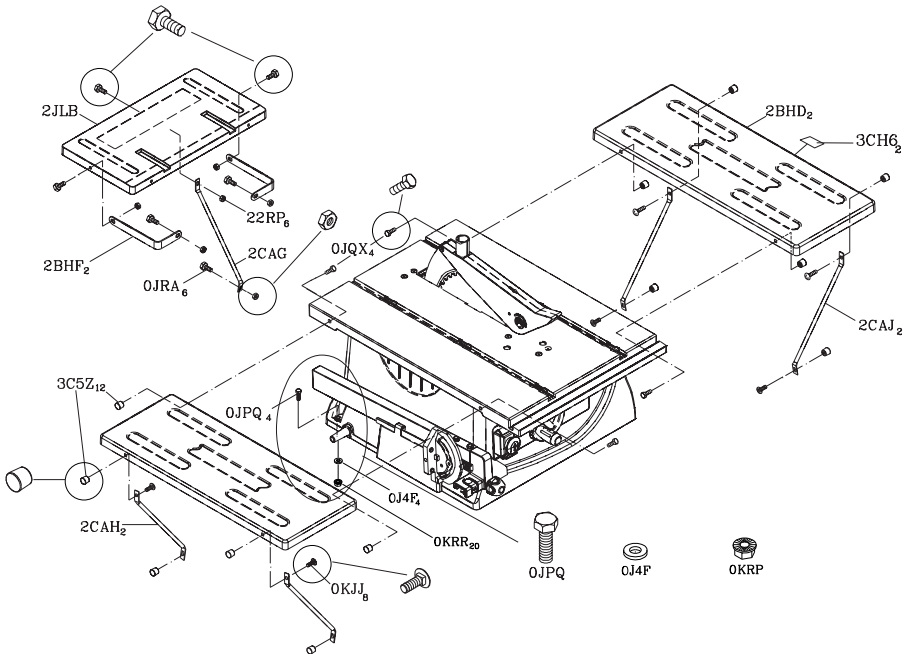

NUTS AND BOLTS REQUIRED FOR THIS ASSEMBLE



3CSZ
X12



0JRA
X 6



22RP
X 6



0JQX
X 4



0KJJ
X 8



0JPQ
X 4



0J4F
X 4



0KRP
X 4

Australia & New Zealand

Stanley Black & Decker

82 Taryn Drive, Epping, VIC 3076 Australia

Tel. 1800 338 002 (Aust) or Tel. 0800 339 258 (NZ)